



WH10000DF

Portable Generator

8000 Running Watts | 10000 Peak Watts
7200 Running Watts | 9000 Peak Watts

SAVE THESE INSTRUCTIONS

Important safety instructions are included in this manual.

WARNING

Operating, servicing and maintaining this equipment can expose you to chemicals including engine exhaust, carbon monoxide, phthalates, and lead, which are known to the State of California to cause cancer and birth defects or other reproductive harm. To minimize exposure, avoid breathing exhaust, do not idle the engine except as necessary, service your equipment in a well-ventilated area and wear gloves or wash your hands frequently when servicing your equipment. For more information go to www.P65Warnings.ca.gov.

DISCLAIMERS:

All information, illustrations and specifications in this manual are based on the latest information available at the time of publishing. The illustrations used in this manual are intended as representative reference views only. Moreover, because of our continuous product improvement policy, we may modify information, illustrations and/or specifications to explain and/or exemplify a product, service or maintenance improvement. We reserve the right to make any change at any time without notice. Some images may vary depending upon which model is shown.

ALL RIGHTS RESERVED:

No part of this publication may be reproduced or used in any form by any means – graphic, electronic or mechanical, including photocopying, recording, taping or information storage and retrieval systems – without the written permission of Westinghouse Outdoor Power Equipment.

DANGER



This manual contains important instructions for operating this generator. For your safety and the safety of others, be sure to read this manual thoroughly before operating the generator. Failure to properly follow all instructions and precautions can cause you and others to be seriously hurt or killed.

TECHNICAL SPECIFICATIONS

| Model Number Número de modelo | Running Watts Wattios de potencia nominal | Peak Watts Wattios de potencia pico | Fuel Tank Size (G/L) Capacidad del depósito de combustible (L/G) | Rated Speed (RPM) Velocidad nominal (RPM) | Ignition Type Tipo de encendido | Spark plug Bujía | Engine Disp (cc) Tamaño del motor (cc) | Stroke X Bore Diámetro y carrera | Oil Capacity (L) Capacidad de aceite (L) | Oil Type Tipo de aceite |
|----------------------------------|----------------------------------------------|----------------------------------------|---------------------------------------------------------------------|----------------------------------------------|------------------------------------|---------------------|-------------------------------------------|-------------------------------------|---------------------------------------------|----------------------------|
| WH10000DF | 8000 Gas 7200 LPG | 10000 Gas 9000 LPG | 6.6G/25L | 3600 | TCI | F7TC | 420 | 66X90 | 1.10 | 10W30 |

NOTICE

Even with a carburetor modification, engine horsepower will decrease about 3.5% for each 300 meter (1,000 foot) increase in altitude. The effect of altitude on horsepower will be greater if no carburetor modification is made. A decrease in engine horsepower will decrease the power output of the generator. Weather will affect engine oil performance. Change the type of engine oil used based on weather conditions to suit the engine needs.

HAVE QUESTIONS?

Email us at service@wpowereq.com
or call 1-855-944-3571

FOR YOUR RECORDS:

| | |
|------------------------------|--|
| Date of Purchase: | |
| Generator Model Number: | |
| Purchased from Store/Dealer: | |
| Generator Serial Number: | |

IMPORTANT: KEEP YOUR PURCHASE RECEIPT TO ENSURE TROUBLE-FREE WARRANTY COVERAGE.

PRODUCT REGISTRATION

To ensure trouble-free warranty coverage, it is important you register your Westinghouse generator. You can register your generator by either:

1. Filling in the product registration form below and mailing to:

Product Registration

Westinghouse Outdoor Power Equipment
 777 Manor Park Drive
 Columbus, Ohio 43228

2. Registering your product Online at www.westinghouseportablepower.com/register-your-product/
 To register your generator you will need to locate the following information:

WHERE IS MY SERIAL NUMBER?

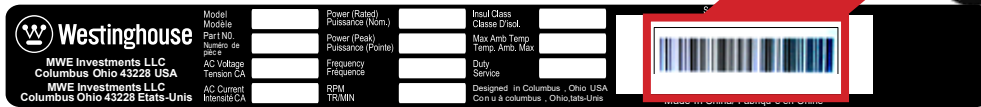

WESTINGHOUSE PRODUCT REGISTRATION FORM

PERSONAL INFORMATION

GENERATOR INFORMATION

First Name: _____ Model Number: _____

Last Name: _____ Serial Number: _____

Street Address: _____ Date Purchased: _____

Street Address: _____ Purchased From: _____

City, State, ZIP: _____

Country: _____

Phone Number: _____

E-Mail: _____



TABLE OF CONTENTS

| | | | |
|----------------------------------------------|----|------------------------------------------|----|
| TECHNICAL SPECIFICATIONS | 2 | MAINTENANCE | 24 |
| PRODUCT REGISTRATION | 3 | Maintenance Schedule | 21 |
| For Your Records: | 3 | Maintenance Reminders on VFT Meter | 25 |
| Product Registration | 3 | Cleaning the Spark Arrestor..... | 25 |
| Product Registration Form | 3 | Draining the Carburetor Float Bowl..... | 25 |
| SAFETY | 5 | Engine Oil Maintenance | 26 |
| Safety Definitions | 5 | Engine Oil Specification | 26 |
| Safety Symbol Definitions | 5 | Checking Engine Oil | 26 |
| General Safety Rules | 6 | Adding Engine Oil | 26 |
| Safety Labels and Decals | 7 | Changing Engine Oil | 27 |
| Fuel Safety..... | 9 | Air Filter Maintenance | 27 |
| UNPACKING | 10 | Cleaning the Air Filter | 27 |
| What Comes in the Box..... | 10 | Spark Plug Maintenance | 28 |
| Wheel Kit Accessories Box | 10 | Checking and Adjusting Valve Lash..... | 29 |
| ASSEMBLY | 11 | Testing GFCI Outlets | 29 |
| Installing Wheels and Feet..... | 11 | Battery Replacement | 29 |
| Installing the Battery | 11 | Cleaning the Generator | 30 |
| FEATURES | 12 | STORAGE | 30 |
| Generator Features | 12 | TROUBLE SHOOTING | 31 |
| Control Panel Features | 14 | EXPLODED AND ENGINE VIEWS | 32 |
| OPERATION | 15 | WH1000DF Exploded View | 32 |
| Before Starting the Generator | 15 | WH1000DF Engine View | 34 |
| Altitude Kit Part Number | 15 | SCHEMATICS | 36 |
| Power Cord | 16 | WH1000DF Schematic | 36 |
| Using Extension Cords | 16 | | |
| Using Westinghouse Power Cord | 16 | | |
| Transfer Switch Connections..... | 17 | | |
| Engine Fluids and Fuel..... | 17 | | |
| Adding Gasoline to the Fuel Tank | 18 | | |
| Connecting to Standard LPG/Propane Tank. . . | 18 | | |
| Connecting to Large LPG/Propane Tank | 19 | | |
| Before Starting the Generator | 19 | | |
| Power Output and Demand..... | 20 | | |
| Starting the Generator on Gas..... | 21 | | |
| Starting the Generator on Propane | 22 | | |
| Stopping the Generator..... | 23 | | |
| Normal Operation | 23 | | |
| During an Emergency | 23 | | |

SAFETY

SAFETY DEFINITIONS

The words DANGER, WARNING, CAUTION and NOTICE are used throughout this manual to highlight important information. Be certain that the meanings of these alerts are known to all who work on or near the equipment.



This safety alert symbol appears with most safety statements. It means attention, become alert, your safety is involved! Please read and abide by the message that follows the safety alerts symbol.

DANGER

Indicates a hazardous situation which, if not avoided, *will* result in death or serious injury.

WARNING

Indicates a hazardous situation which, if not avoided, *could* result in death or serious injury.

CAUTION

Indicates a hazardous situation which, if not avoided, *could* result in minor or moderate injury.

NOTICE

Indicates a situation which can cause damage to the generator, personal property and/or the environment, or cause the equipment to operate improperly.

NOTE: Indicates a procedure, practice or condition that should be followed in order for the generator to function in the manner intended.

SAFETY SYMBOL DEFINITIONS

| Symbol | Description |
|-------------------------------------------------------------------------------------|------------------------------------------|
|  | Safety Alert Symbol |
|  | Asphyxiation Hazard |
|  | Burn Hazard |
|  | Burst/Pressure Hazard |
|  | Don't leave tools in the area |
|  | Electrical Shock Hazard |
|  | Explosion Hazard |
|  | Fire Hazard |
|  | Lifting Hazard |
|  | Pinch-Point Hazard |
|  | Read Manufacturer's Instructions |
|  | Read Safety Messages Before Proceeding |
|  | Wear Personal Protective Equipment (PPE) |

SAFETY

GENERAL SAFETY RULES

DANGER



Never use the generator in a location that is wet or damp. Never expose the generator to rain, snow, water spray or standing water while in use. Protect the generator from all hazardous weather conditions. Moisture or ice can cause a short circuit or other malfunction in the electrical circuit.



Never operate the generator in an enclosed area. Engine exhaust contains carbon monoxide. Only operate the generator outside and away from windows, doors and vents.

WARNING



Voltage produced by the generator could result in death or serious injury.

- Never operate the generator in rain or a flood plain unless proper precautions are taken to avoid being subject to rain or a flood.
- Never use worn or damaged extension cords.
- Always have a licensed electrician connect the generator to the utility circuit.
- Never touch an operating generator if the generator is wet or if you have wet hands.
- Never operate the generator in highly conductive areas such as around metal decking or steel works.
- Always use grounded extension cords. Always use three-wire or double-insulated power tools.
- Never touch live terminals or bare wires while the generator is operating.
- Be sure the generator is properly grounded before operating.

WARNING



Gasoline and gasoline vapors are extremely flammable and explosive under certain conditions.

- Always refuel the generator outdoors, in a well-ventilated area.
- Never remove the fuel cap with the engine running.
- Never refuel the generator while the engine is running. Always turn engine off and allow the generator to cool before refueling.
- Only fill fuel tank with gasoline.
- Keep sparks, open flames or any other forms of ignition (such as match, cigarette, static electric source) away when refueling.
- Never overfill the fuel tank. Leave room for fuel to expand. Overfilling the fuel tank can result in a sudden overflow of gasoline and result in spilled gasoline coming in contact with HOT surfaces. Spilled fuel can ignite. If fuel is spilled on the generator, wipe up any spills immediately. Dispose of rag properly. Allow area of spilled fuel to dry before operating the generator.
- Wear eye protection while refueling.
- Never use gasoline as a cleaning agent.
- Store any containers containing gasoline in a well-ventilated area, away from any combustibles or source of ignition.
- Check for fuel leaks after refueling. Never operate the engine if a fuel leak is discovered.



WARNING



Never operate the generator if powered items overheat, electrical output drops, there is sparking, flames or smoke coming from the generator, or if the receptacles are damaged.



Never use the generator to power medical support equipment.



Always remove any tools or other service equipment used during maintenance from the generator before operating.

NOTICE

Never modify the generator.

Never operate the generator if it vibrates at high levels, if engine speed changes greatly or if the engine misfires often.

Always disconnect tools or appliances from the generator before starting.

SAFETY

SAFETY LABELS AND DECALS

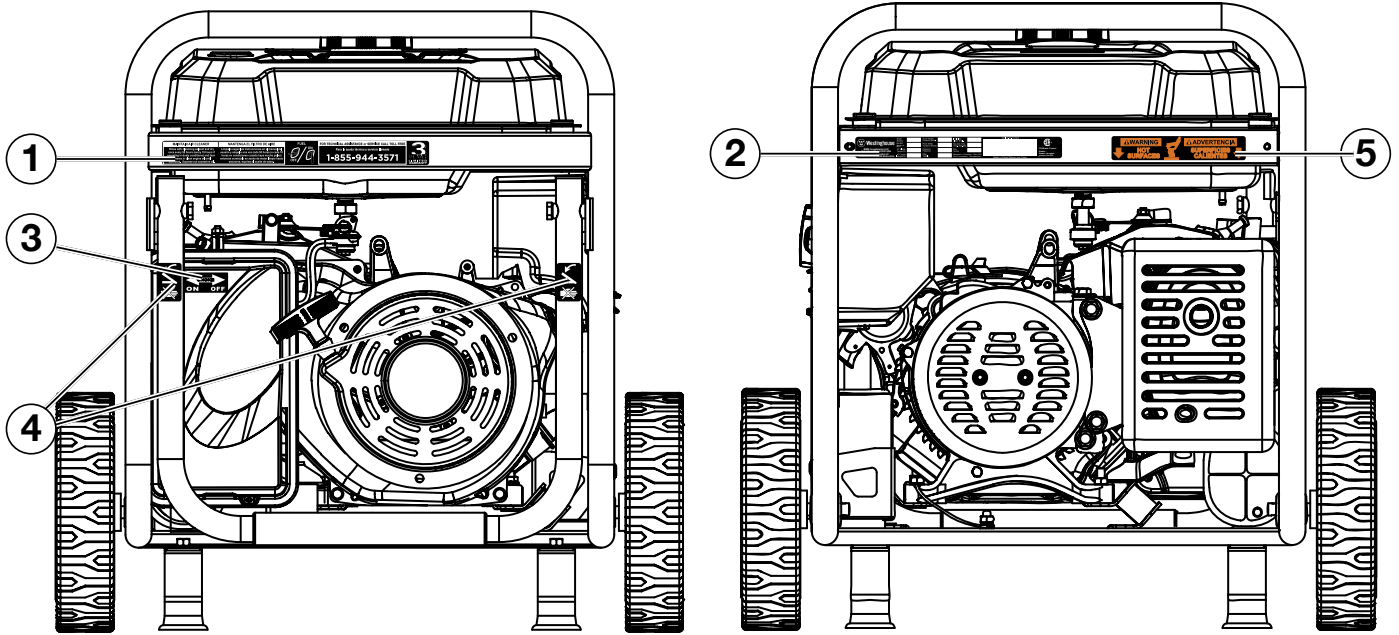

| | | | | | |
|---|----------------------------------------------------------------------------------------------------------------------------------------------------------------------------------------------------------------------------|-----------------------------------------------------------------------------------------------------------------------------------------------------------------------------------------------------------------------------------------------------------------------------------|-------------------|--------------------------------------------------------------------------------------------------------------------------------|-----------------------------------------|
| 1 | MAINTAIN AIR CLEANER Rinse with cleansing solvent and dry once every 50 hours (every 10 hours if operating in dusty conditions) and then immerse in clean engine oil until saturated. Squeeze out excessive oil. | MANTENGA EL FILTRO DE AIRE Limpielo según las instrucciones en el manual del usuario y séquelo una vez cada 50 horas (o cada 10 horas en condiciones cuando haya mucho polvo) entonces sumérgalo en aceite de motor limpio hasta saturarse, exprima el aceite de sobra. | FUEL ON OFF | FOR TECHNICAL ASSISTANCE or SERVICE CALL TOLL FREE Para la ayuda técnica y servicio llamada 1-855-944-3571 | 3 YEAR LIMITED WARRANTY |
| | | | | | |

| | | | | |
|---|-----------------------------------------------------------------------------------------------------------------------------------------------------------------|------------------------------------------|---------------------------------------------------------------------|----------------------------------------------------------------------|
| 2 | Westinghouse Model _____ Part No. _____ MWE Investments LLC Columbus Ohio 43228 USA MWE Investments LLC Columbus Ohio 43228 Etats-Unis | Power (Rated) Puissance (Nom.) _____ | Inul Class Classe Dissd. _____ | Serial No./No. De Série _____ Made in China/ Fabriqué en Chine |
| | | Power (Peak) Puissance (Pointe) _____ | Max Amb Temp Temp. Amb. Max _____ | |
| | AC Voltage Tension CA _____ | Frequency Frecuencia _____ | Duty Service _____ | |
| | AC Current Intensité CA _____ | RPM TR/MIN _____ | Designed in Columbus, Ohio USA Con u à columbus, Ohio,Etats-Unis | |

| | | |
|---|--------------------------------------------------------------------------------------------------------------------------------------------------------------------------------------------------------------------------------------------------------------------------------------------------------|-----------------------------------------------------------------------------------------------------------------------------------------------------------------------------------------------------------------------------------------------------------------------------------------------------------------------------------------------------------------------|
| 3 | ⚠ DANGER Read owners manual before operating generator on LPG/propane. LPG/Propane is highly flammable. Leaking LP-gas can cause a fire or explosion if ignited. If you smell propane while you are operating unit, immediately shut off propane valve. Keep propane tank away from exhaust. | ⚠ PELIGRO Lea el manual del propietario antes de operar el generador con GLP / propano. GLP / propano es altamente inflamable. La fuga de gas LP puede causar un incendio o una explosión si se enciende. Si huele a propano mientras está operando la unidad, apague inmediatamente la válvula de propano. Mantenga el tanque de propano lejos del escape. |
| | | |

| | | |
|---|-----------------------------------------|------------------------------------------------------|
| 4 | ⚠ WARNING HOT SURFACES | ⚠ ADVERTENCIA SUPERFICIES CALIENTES |
| | | |

| | | | |
|---|--|---|--|
| 5 | | 6 | |
| | | | |

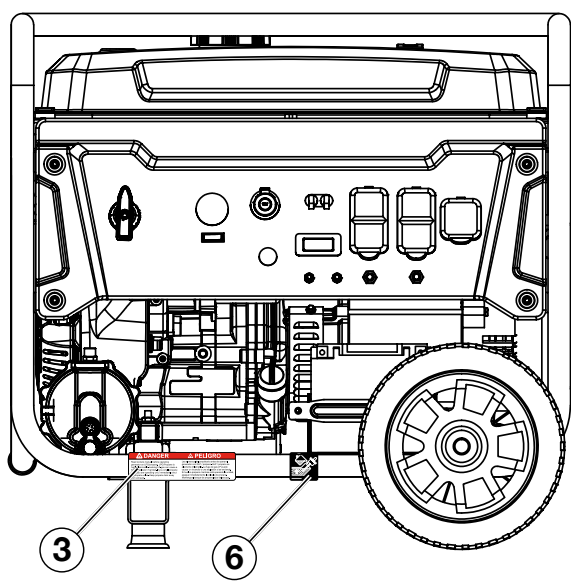

SAFETY

SAFETY LABELS AND DECALS

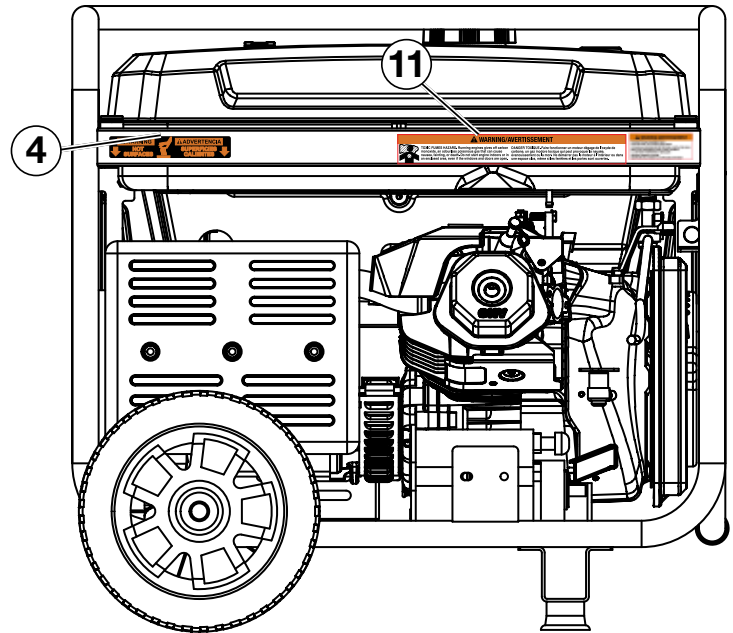
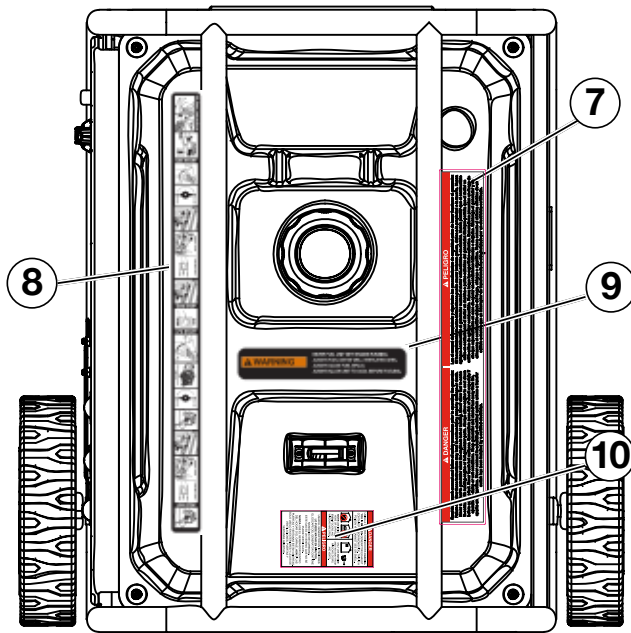

7 **⚠ DANGER** **⚠ PELIGRO**

Read the owner's manual and follow all safety procedures prior to operating the generator. Failure to follow these instructions may lead to serious injury, property damage or death. Never add fuel to generator when the engine is hot or running. Never allow fuel to come in contact with running engine or hot generator parts. Always allow engine to cool down before adding fuel. Never touch hot surfaces. Generators pose risk of shock especially if operated in damp or wet conditions. Keep generator and stored fuel away from fire, sparks and cigarettes. Never connect to a building's electrical system unless a transfer switch has been installed by a certified electrician.

Lea el manual del propietario y siga todos los procedimientos de seguridad antes de hacer funcionar el generador. El incumplimiento de estas instrucciones puede causar lesiones graves, daños a la propiedad o la muerte. Nunca agregue combustible al generador cuando el motor está caliente o en marcha. Nunca permita que el combustible entre en contacto con el motor en marcha o partes calientes del generador. Siempre permita que el motor se enfríe antes de agregar combustible. Nunca toque las superficies calientes. Generadores presentan un riesgo de choque especialmente en caso de operar en condiciones húmedas o mojadas. Mantenga el generador y su almacena el combustible alejado del fuego, chispas o cigarrillos. Nunca conecte al sistema eléctrico de un edificio a menos que un interruptor de transferencia ha sido instalado por un electricista certificado.



9 **⚠ WARNING**

NEVER FUEL UNIT WITH ENGINE RUNNING. ALWAYS FUEL UNIT IN WELL VENTILATED AREA. ALWAYS CLEAN FUEL SPILLS. ALWAYS ALLOW UNIT TO COOL BEFORE FUELING.

10 **⚠ DANGER** **⚠ PELIGRO**

USING A GENERATOR INDOORS CAN KILL YOU IN MINUTES. GENERATOR EXHAUST CONTAINS CARBON MONOXIDE, THIS IS A POISON YOU CANNOT SEE OR SMELL.

USAR EL GENERADOR EN INTERIORES LO PUEDE MATAR EN MINUTOS. EL ESCAPE DEL GENERADOR CONTIENE MONÓXIDO DE CARBONO, ESTE GAS ES UN VENENO QUE NO SE PUEDE VER NI OLER.

NEVER USE INSIDE A HOME OR GARAGE, EVEN IF DOORS AND WINDOWS ARE OPEN. ONLY USE OUTSIDE AND FAR AWAY FROM WINDOWS, DOORS, AND VENTS.

NUNCA USE EL GENERADOR DENTRO DEL HOGAR O EL GARAJE, AÚN SI LAS PUERTAS Y VENTANAS ESTÁN ABIERTAS. SOLO ÚSELO EN EXTERIORES Y LEJOS DE VENTILACIONES, PUERTAS Y VENTANAS ABIERTAS.

11 **⚠ WARNING/ADVERTENCIA**

TOXIC FUMES HAZARD. Running engines give off carbon monoxide, an odorless poisonous gas that can cause nausea, fainting, or death. Do not start engine indoors or in an enclosed area, even if the windows and doors are open.

PELIGRO DE VAPORES TÓXICOS. Los motores en funcionamiento emiten monóxido de carbono, un gas venenoso inodoro que puede causar náuseas, desmayos o la muerte. No encienda el motor en interiores ni en un área cerrada, incluso si las ventanas y las puertas están abiertas.

⚠ WARNING/ADVERTENCIA

- For electrical equipment only
- Solo para equipo eléctrico
- For use in a weather protected well ventilated area
- Para uso en un área bien ventilada y protegida del clima
- Neutral bonded to frame
- Neutro unido al marco

SAFETY

FUEL SAFETY

DANGER



Gasoline and liquid petroleum gas (LPG) are highly explosive and flammable. Explosions and fire can cause severe burns or death.

Gasoline and gasoline vapor (Gas)

- Gasoline is highly flammable and explosive.
- Gas expands and contracts with different temperatures.
- In case of a gas fire, do not attempt to extinguish the flame if the fuel shutoff valve is in the on position. Introducing an extinguisher to a generator with an open fuel valve could create an explosion hazard.
- Gas has a distinctive odor, this will help detect potential leaks quickly.
- Gas vapors can cause a fire if ignited.
- Gasoline is a skin irritant and needs to be cleaned up immediately if it comes in contact with the skin.

Liquid Petroleum Gas (Propane/LPG)

- LPG/Propane is highly flammable and explosive.
- Flammable gas under pressure can cause a fire or explosion if ignited.
- LPG/Propane can settle in low places because it is heavier than air.
- LPG/Propane has a distinctive odor added to help detect potential leaks.
- Always keep LPG/Propane tank in an upright position.
- When exchanging LPG/Propane tanks, be sure the tank value is the same type.
- In case of a LPG/Propane fire, do not attempt to extinguish unless the fuel supply can be shut off.
- LPG/Propane will burn the skin. Prevent skin contact at all times.

WARNING



Never use a gas container, LPG connector hose, LPG tank or any other fuel item that appears to be damaged.

When starting generator:

- Make sure that the gas cap, air filter, spark plug, fuel lines and exhaust system are properly in place.
- If you spill any gasoline on the tank, allow it to fully evaporate before operating.
- Make sure the generator and propane tank are on a flat surface before operating.
- If there is a propane odor do not start the unit because there may be a potential leak.
- Never place propane tank near engine exhaust.

When transporting or servicing the generator:

- Make certain the fuel shutoff valve is off and the fuel tank is empty.
- Make sure the LPG tank and LPG hose is not attached to the generator.
- Disconnect the spark plug wire.

When storing the generator:

- Store away from sparks, open flames, pilot lights, heat and other sources of ignition.
- Do not store gas or LPG tank near furnaces, water heaters or any other appliances that produce heat or have automatic ignitions.

CAUTION



Only use approved LPG tanks with OPD (overfilling prevention device) valve. Always keep the tank in a vertical position with the valve on top and installed at ground level on a flat surface. Do not allow tanks to be around any heat source and make sure it is not exposed to the sun, rain and dust. When transporting and storing, turn off the tank valve and fuel valve, and disconnect the tank. Make sure to always cover the generator and tank outlet with protective plastic caps.

CAUTION



Do not allow children to tamper or play with the propane tank or hose connections.

WARNING



If there is a strong smell of propane while operating the generator close the valve on the propane tank immediately. Once the propane is off, use soapy water to check for leaks on the hose and connections on the tank valve and the generator. Do not smoke or light a cigarette or check for leaks using any open flame source such as a match or lighter. If a leak is found contact a qualified technician to inspect and repair the LPG system before using the generator.

UNPACKING

⚠ CAUTION

 Always have assistance when lifting the generator. The generator is heavy; lifting it could cause bodily harm.

 Avoid cutting on or near staples to prevent personal injury.

Tools required – box cutter or similar device.

1. Carefully cut the packing tape on top of the carton.
2. Fold back top flaps to reveal the manual.
3. Remove the Wheel Kit Accessories cardboard box.
4. Carefully cut two sides of the carton to remove the generator.

WHAT COMES IN THE BOX

- Manual
- Quick Start Guide/Maintenance Schedule
- 1.1 Liter Bottle of SAE 10W30 Oil (1)
- LPG Hose (1)
- Spark Plug Socket Wrench (1)
- Wheel Kit Accessories Box
- Funnel (1)

WHEEL KIT ACCESSORIES BOX

Open the Wheel Kit Accessories box and verify the contents against the list right. If any parts are missing, please locate an authorized Westinghouse Generator dealer at service@wpowerreq.com or call 1-855-944-3571.

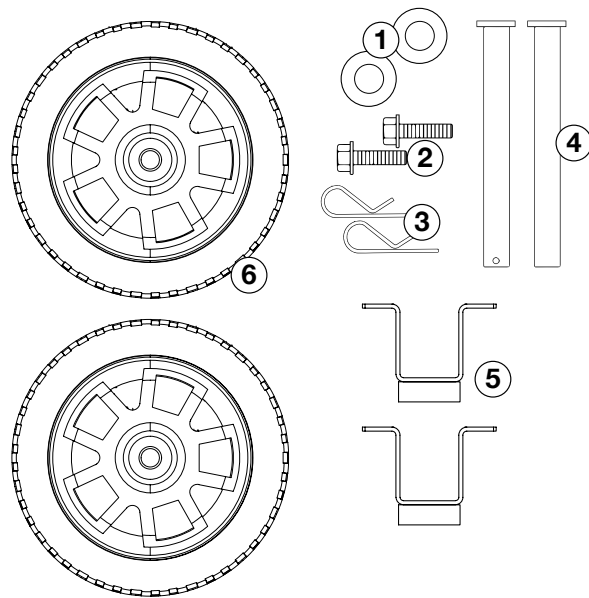

Figure 1 -Wheel and Feet Kit Hardware

1. Washer (2 used)
2. Flange Bolt M8 x16mm (4 used)
3. Hairpin Cotter Pin (2 used)
4. Wheel Axle Pin (2)
5. Mounting feet (2)
6. Wheel (2)



LPG hose is shipped under fuel tank on opposite side of generator



ASSEMBLY

INSTALLING WHEELS AND FEET



BEFORE ASSEMBLING THE GENERATOR, REVIEW THE SAFETY SECTION STARTING ON PAGE 5.

⚠ CAUTION



Never lift the generator without assistance. The generator is heavy and lifting without assistance could result in personal injury.



Never use the handles as a lifting point to support the entire weight of the generator. Only use the handles to move the generator by lifting the handles and using the wheels to move the generator.



Use caution when collapsing the handles. Hands and fingers could get caught and pinched.

NOTICE

Assembling the generator will require lifting the unit on one side. Make sure all engine oil and fuel are drained from the unit prior to assembling. Once assembled, the wheel kit is not intended for on-road use. The wheel kit is designed for use on this generator only.

INSTALLING FEET TO FRAME

1. Place generator on a flat surface.
2. Place a piece of cardboard or other soft material to tip the generator onto, to protect the frame paint and prevent the generator from sliding. Tip the generator onto the side.
3. Install the mounting foot (5) to the frame using M8 flange bolts (2).

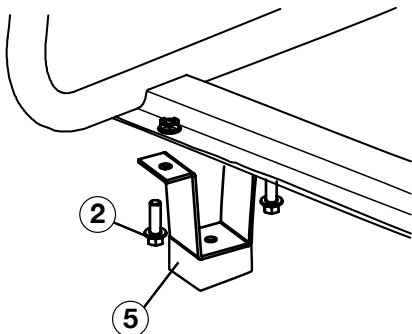

Figure 1 - Assemble Mounting Feet to Frame

INSTALLING WHEELS TO FRAME

1. Insert axle pin (4) through wheel (6) and place washer (1) between wheel and mounting bracket.

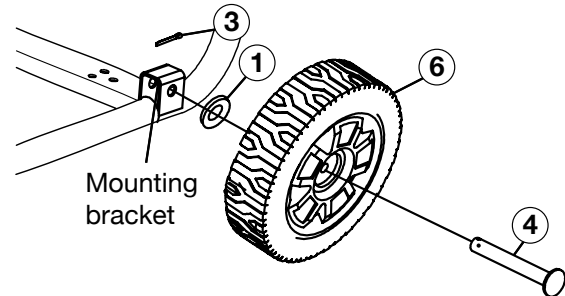

Figure 2 - Wheel Assembly

2. Place hairpin cotter pin (3) through the eye of the wheel axle pin (4) to secure wheel.
3. Repeat previous steps on other wheel.

INSTALLING THE BATTERY

⚠ WARNING



To avoid electric shock:

- ALWAYS connect the positive (+) battery cable (red boot) first when connecting battery cables.
- ALWAYS disconnect the negative (-) battery cable (black boot) first when disconnecting battery cables.
- NEVER connect the negative (-) battery cable (black boot) to the positive (+) post on the battery.
- NEVER connect the positive (+) battery cable (red boot) to the negative (-) post on the battery.
- NEVER touch both battery posts simultaneously.
- NEVER place a metal tool across both battery posts.
- ALWAYS use insulated or nonconducting tools when installing the battery.

1. Verify the positive (+) battery cable (red boot) is securely tightened to the positive (+) battery post. Make sure boot is over battery post.
2. Clip the battery quick connects ends together to connect battery.

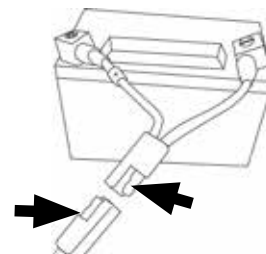

Figure 3 - Connect Battery

FEATURES



- ① **Fuel Selector Switch:** Used to select and turn on gasoline or propane fuel source.
- ② **Electric Start Switch:** Hold in Start position for 1 second to start engine. Make sure to turn choke on prior to cold starting.
- ③ **Fuel Cap:** Close until clicking sound is heard.
- ④ **Control Panel:** Contains the circuit breakers and outlets.
- ⑤ **Oil Fill Plug/Dipstick:** Must be removed to add and check oil.
- ⑥ **Oil Drain Plug:** Must be removed to drain engine oil
- ⑦ **Never Flat Wheels:** For easy portability
- ⑧ **Fuel Shut off Valve:** Controls the flow of fuel to the engine.
- ⑨ **Manual Choke:** Choke must be set manually by adjusting choke lever.
- ⑩ **Single Piece Handle:** Includes rubber grip. Allows you to easily push or pull unit with one hand.

FEATURES



- ① **Fuel Gauge:** Indicates fuel level.
- ② **Spark Plug Boot (Wire):** Must be removed when servicing the engine or the spark plug.
- ③ **Muffler and Spark Arrester:** Avoid contact until engine is cooled down. Spark arrester prevents sparks from exiting the muffler. It must be removed for servicing.

FEATURES

CONTROL PANEL FEATURES

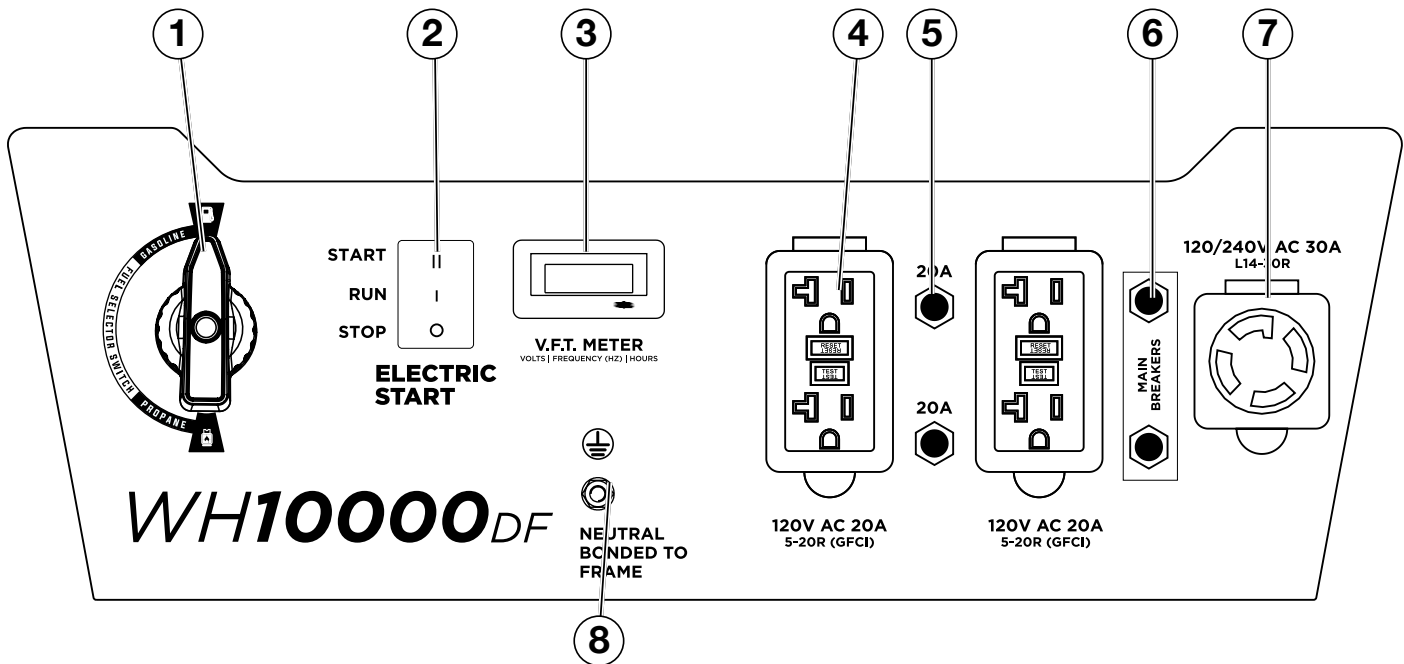

- ① **Fuel Selector Switch:** Select and turn on gas or propane.
- ② **Electric Start Switch:** Hold in Start until engine starts. Make sure to manually open choke prior to starting.
- ③ **Data Center:** The VFT Meter is 4 state LED display that will rotate through volts, frequency, and lifetime run hours. The 4th display is used for maintenance reminders and may display as 00:00. You can press the **MODE** button to cycle through the different displays. The meter will display volts and hertz even if there is no load connected.

The frequency and voltage can vary +/- 5% and still be within tolerance.

| | |
|-------|-----------------------|
| U250 | Voltage |
| F-60 | Frequency in hertz |
| 00:07 | Lifetime run hours |
| 0P:50 | Maintenance Reminders |

- ④ **120-Volt, 20-Amp Duplex GFCI Outlets (NEMA 5-20R):** Each outlet is capable of carrying a maximum of 20 amps on a single receptacle or a combination of both receptacles.
- ⑤ **20-Amp Circuit Breakers:** Each circuit breaker limits the current that can be delivered through the 120-volt duplex outlets to 20amps.
- ⑥ **25-Amp Circuit Breakers:** Each push button circuit breaker controls total output per leg to L14-30 receptacle.
- ⑦ **120/240-Volt, 30-Amp Twist Lock Outlet (NEMA L14-30R):** Outlet can supply either 120V or 240V output.
- ⑧ **Ground Terminal:** The ground terminal is used to ground the generator.

OPERATION

BEFORE STARTING THE GENERATOR



BEFORE STARTING THE GENERATOR, REVIEW SAFETY SECTION STARTING ON PAGE 5.

Location Selection – Before starting the generator, avoid exhaust and location hazards by verifying:

- You have selected a location to operate the generator that is outdoors and well ventilated.
- You have selected a location with a level and solid surface on which to place the generator.
- You have selected a location that is at least 15 feet (4.5 m) away from any building, other equipment or combustible material.
- If the generator is located close to a building, make sure it is not located near any windows, doors and/or vents.

| ⚠ DANGER | |
|----------------------------------------------------------------------------------------------------------------------------------------------------------|--------------------------------------------------------------------------|
| Using a generator indoors CAN KILL YOU IN MINUTES. Generator exhaust contains carbon monoxide. This is a poison you cannot see or smell. | |
| NEVER use inside a home or garage, EVEN IF doors and windows are open. | Only use OUTSIDE and far away from windows, doors, and vents. |
| Avoid other generator hazards. READ MANUAL BEFORE USE. | |

| ⚠ WARNING | |
|------------------|---------------------------------------------------------------------------------------------------------------------------------------------------------------------------------------------------------------------------------------------------------------------|
| | Always operate the generator on a level surface. Placing the generator on non level surfaces can cause the generator to tip over, causing fuel and oil to spill. Spilled fuel can ignite if it comes in contact with an ignition source such as a very hot surface. |

| NOTICE | |
|---------------------------------------------------------------------------------------------------------------------------------------------------------------------------------------------------------------------------------------------------------------------------------------------------------------------|--|
| Only operate the generator on a solid, level surface. Operating the generator on a surface with loose material such as sand or grass clippings can cause debris to be ingested by the generator that could: <ul style="list-style-type: none">• Block cooling vents• Block air intake system | |

Weather – Never operate your generator outdoors during rain, snow or any combination of weather conditions that could lead to moisture collecting on, in or around the generator.

Dry Surface – Always operate the generator on a dry surface free of any moisture.

No Connected Loads – Make sure the generator has no connected loads before starting it. To ensure there are no connected loads, unplug any electrical extension cords that are plugged into the control panel receptacles.

| NOTICE |
|-------------------------------------------------------------------------------------------------------------------------------------------------------------------|
| Starting the generator with loads already applied to it could result in damage to any appliance being powered off the generator during the brief start-up period. |

Grounding the Generator – The National Electric Code (NEC), as well as many local electrical codes, may require the generator to be connected to earth ground. The most common application that requires a ground rod is when you are using the generator as a separately derived system to provide back up power to your house. Typically this is when a transfer switch has a switched neutral.

As the generator application has many variables that cannot be determined by the manufacturer of the generator, a licensed electrician will need to determine if a grounding rod is needed.

If a licensed electrician has determine the application requires a ground rod, make sure it is connected to earth ground by connecting the ground terminal on the control panel to earth ground using copper wire (minimum 10 AWG). Consult a qualified electrician for local grounding requirements.

Neutral Bonded: There is a permanent conduct or between the generator (stator winding) and the frame.

| ⚠ WARNING | |
|------------------|--------------------------------------------------------------------------------------------------------------------------------------------------------------------|
| | Be sure the generator is properly connected to earth ground before operating. The generator must be grounded to prevent electrical shock due to faulty appliances. |

High Altitude Operation

Engine power is reduced the higher you operate above sea level. Output will be reduced approximately 3.5% for every 1000ft of increased altitude from sea level. This is a natural occurrence and cannot be adjusted by engine. Increased exhaust emissions can also result due to increased fuel mixture. Other issues include hard starting, increased fuel consumption and spark plug fouling. Contact our service team **1-855-944-3571** for altitude part kits.

High Altitude Carburetor Kit Part Number: 140571

High Altitude DF Regulator Part Number: 140565

OPERATION

POWERCORD

Using Extension Cords

Westinghouse Outdoor Power Equipment assumes no responsibility for the content within this table. The use of this table is the responsibility of the user only. This table is intended for reference only. The results produced by using this table are not guaranteed to be correct or applicable in all situations as the type and construction of cords are highly variable. Always check with local regulations and a licensed electrician prior to installing or connecting an electrical appliance.

Extension Cord Wire Gauge Size

| AMPS | LENGTH OF EXTENSION CORD (ft) | | | | | | | | |
|------|-------------------------------|----|----|----|----|----|----|-----|-----|
| | 10 | 20 | 30 | 40 | 50 | 60 | 80 | 100 | 120 |
| 5 | 20 | 18 | 16 | 14 | 12 | 12 | 10 | 10 | 8 |
| 10 | 18 | 16 | 14 | 12 | 12 | 10 | 10 | 8 | 8 |
| 15 | 16 | 14 | 12 | 12 | 10 | 10 | 8 | 8 | 6 |
| 20 | 14 | 12 | 12 | 10 | 10 | 8 | 8 | 6 | 6 |
| 25 | 12 | 12 | 10 | 10 | 8 | 8 | 6 | 6 | 6 |
| 30 | 12 | 10 | 10 | 8 | 8 | 6 | 6 | 6 | 6 |
| 35 | 10 | 10 | 8 | 8 | 6 | 6 | 6 | 6 | 6 |

Using Westinghouse Power Cord

Use the extension cord chart to determine the size of the conductor for extension cord applications. Determine the distance of the generator to the appliance on the top line of the chart. Then select the rated amperage of the generator on the left side of the chart. Where the two meet is the size of the conductor required for the application.

The Westinghouse power cord (shown right) is connected to the generator at the L14-30R 120/240 plug. The opposite end of the power cord is a fan tail receptacle with 2 green receptacles and 2 red receptacles. Each receptacle is rated at 120 volts AC. To balance the load on the generator's alternator, use the red and green identifiers on the fan tail receptacle. To keep the load balanced, connect the loads so that both color receptacles are used. An example is one in red and one in green. Do not connect 2 in red and none in green, or 2 in green and none in red. If only one color receptacle is used with multiple loads, the alternator may experience an unbalanced load, causing undue vibration to generator.

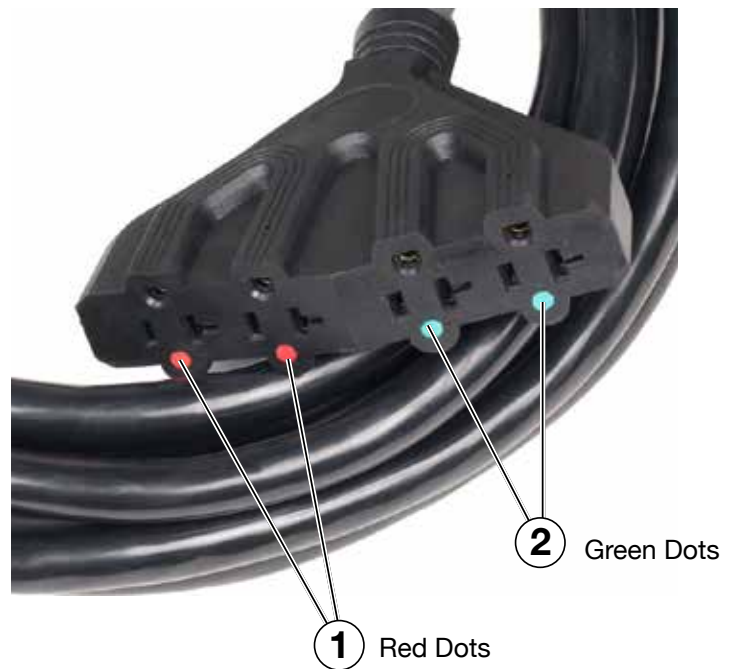

Figure 4 - Fan Extension Cord

OPERATION

CONNECTING THE GENERATOR TO A BUILDING ELECTRICAL SYSTEM

It is recommended to use a manual transfer switch when connecting directly to a buildings electrical system. Connecting a portable generator to a buildings electrical system must be made in strict compliance with all national and local electrical codes and laws, and be completed by a qualified electrician.

TRANSFER SWITCH CONNECTIONS

The Westinghouse generator is wired with the neutral bonded to ground. If you are connecting your generator to a panel board transfer switch, a licensed electrician will need to consider removing the bonded neutral to ensure proper operation of household GFCI circuits. Begin by removing the alternator cover. Once the cover is off remove the nut that holds the bonded ground jumper wire (see “2” in Figure 5). Once the nut is removed take the bonded jumper wire off and re-secure the nut. Next remove the screw holding the neutral ground wire (see “1” in Figure 5). Attach the bonded jumper wire (2) to the neutral ground (1) and tighten the screw.

If the bonded neutral is removed the generator must be relabeled as floating neutral on the control panel.

If your generator is equipped with GFCI receptacles, removing the bonded neutral may not allow proper operation of the GFCI receptacles. Always keep the jumper wire in case it is needed for future use when not connected to a transfer switch.

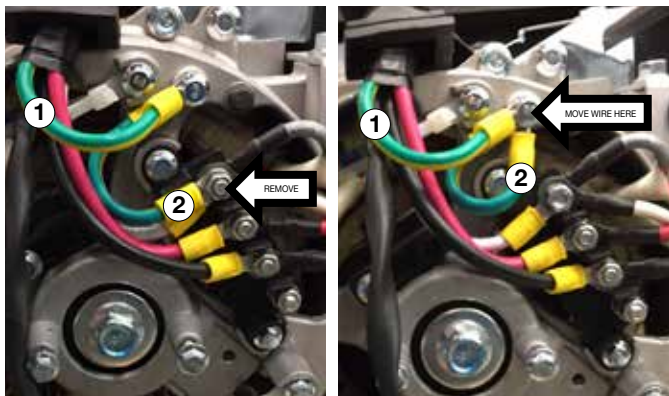

- ① Alternator Neutral Ground Wire (white/Green)
- ② Alternator Bonded Jumper Wire (white/Green)

Figure 5

ADDING / CHECKING ENGINE FLUIDS AND FUEL



BEFORE ADDING/CHECKING ENGINE FLUIDS AND FUEL, REVIEW SAFETY SECTION STARTING ON PAGE 5.

⚠ DANGER



Filling the fuel tank with gasoline while the generator is running can cause gasoline to leak and come in contact with hot surfaces that can ignite the gasoline.

Before starting the generator, always check the level of:

- Engine oil
- Gasoline in the fuel tank

Once the generator is started and the engine gets warm, it is not safe to add gasoline to the fuel tank or engine oil to the engine while the engine is running or the engine and muffler are hot.

CHECKING AND / OR ADDING ENGINE OIL

⚠ WARNING



Internal pressure can build in the engine crankcase while the engine is running. Removing the oil fill plug/ dipstick while the engine is hot can cause extremely hot oil to spray out of the crankcase and can severely burn skin. Allow engine oil to cool for several minutes before removing the oil fill plug/dipstick.

The unit as shipped does not contain oil in the engine. You must add engine oil before starting the generator for the first time. See *Checking Engine Oil* and *Adding Engine Oil* for instructions on checking engine oil level and the procedure for adding engine oil.

NOTICE

The engine does not contain engine oil as shipped. Attempting to start the engine can damage engine components. The owner of the generator is responsible to ensure the proper oil level is maintained during the operation of the generator. Failure to maintain the proper oil level can result in engine damage.

NOTICE

During the first five hours of operating the generator make sure to not exceed 50% of the rated running watts until the unit is broken in properly. Make sure to vary to load occasionally to allow stator windings to heat and cool. Adjusting the load will also help seat piston rings. Check oil more often during the first couple times of operating the generator.

NOTICE

Weather will affect engine oil performance. Change the type of engine oil used based on weather conditions to suit the engine needs.

OPERATION

ADDING GASOLINE TO THE FUEL TANK



**BEFORE ADDING GAS TO THE TANK
PLEASE REVIEW FUEL SAFETY
SECTION ON PAGE 9**

WARNING



Never refuel the generator while the engine is running.



Always turn the engine off and allow the generator to cool before refueling.

Required Gasoline – Only use gasoline that meets the following requirements:

- Unleaded gasoline only
- Gasoline with maximum 10% ethanol added
- Gasoline with an 87 octane rating or higher

Filling the Fuel Tank – Follow the steps below to fill the fuel tank:

1. Shut off the generator.
2. Allow the generator to cool down so all surface areas of the muffler and engine are cool to the touch.
3. Move the generator to a flat surface.
4. Clean area around the fuel cap.
5. Remove the fuel cap by rotating counterclockwise.
6. Slowly add gasoline into the fuel tank. Be very careful not to overfill the tank. The gasoline level should NOT be higher than the filler neck (see Figure 7).
7. Install the fuel cap by rotating clockwise until you hear a click, indicating the cap is completely installed.

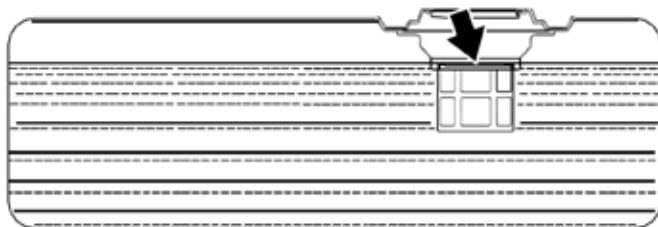

Figure 6 - Maximum Gasoline Fill Level

CAUTION



Avoid prolonged breathing of gasoline vapors.

CONNECTING TO STANDARD LPG/PROPANE TANK



**BEFORE CONNECTING PROPANE TANK TO
THE GENERATOR PLEASE REVIEW FUEL
SAFETY SECTION ON PAGE 9**

Connecting LPG Tank

1. Make sure the generator is off, on a flat surface in well ventilated area.
2. Make sure propane tank valve is in the off position.
3. Make sure the fuel selector switch on the generator control panel is pointing downward to “Propane”.
4. Remove the plastic cover on the generator propane inlet valve.
5. Using your fingers tighten the LPG hose (included) end below to the generator propane inlet. **DO NOT OVERTIGHTEN 35-88 lb-in maximum.**

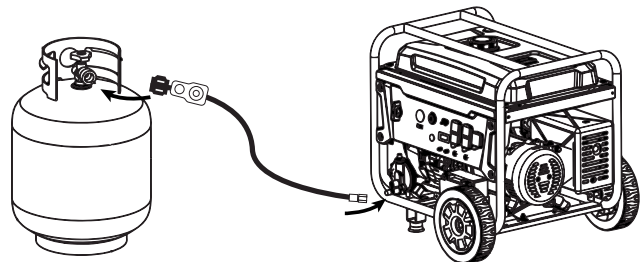

6. Attach the other end of the hose to a tank of LPG/Propane and hand tighten.
7. Check all connections for leaks by wetting the fittings with soapy water. Anywhere that bubbles appear or grow indicates a leak in the connection. If a leak exists at a fitting then turn off the tank valve and tighten the fitting. Turn the gas back on and recheck with soapy water again. If the leak continues or if the leak is not at a fitting then do not use the generator and contact customer service.

NOTICE

- When using standard 20 or 30 pound capacity LPG tanks, make sure they have Type 1, right hand Acme threads.
- Verify the requalification date on the tank has not expired.
- All new tanks must be purged of air and moisture prior to filling. Used tanks that have not been plugged or kept closed must also be purged
- The purging process should be done by a LPG supplier. (Tanks from an exchange supplier should have been purged and filled properly already)
- Always position the tank so the connection between the valve and the gas inlet won't cause sharp bends or kinks in the hose.

WARNING



Do not start generator if you smell propane. This may result in explosion hazard. Do not use provided LPG hose for any other appliances. Always turn off the propane tank and disconnect LPG hose when not in use.

OPERATION

CONNECTING TO LARGE LPG/PROPANE TANK BEFORE CONNECTING PROPANE TANK TO THE GENERATOR PLEASE REVIEW FUEL SAFETY SECTION ON PAGE 9



You can hook up your Duel Fuel Generator to a large home LP tank. It is required that you consult a plumber to properly connect your generator to the tank.

To properly connect with a large propane tank you must first check and confirm the LP fuel pressure at the outlet of the LP tank. The LP fuel pressure should be 14-10" of water column, which is the standard fuel pressure for residential gas fired appliances.

If the LP fuel pressure is within the 14-10" water column range, the primary fuel regulator should be removed from the fuel line components. Then plumb directly from the LP tank to the secondary regulator assembled to the generator.

WARNING



You must consult a certified plumber to connect to large LP tank safely.

BEFORE STARTING THE GENERATOR



**BEFORE STARTING THE GENERATOR,
REVIEW SAFETY SECTION STARTING ON
PAGE 5.**

Before attempting to start the generator, verify the following:

- The engine is filled with engine oil.
- The generator is situated in a proper location.
- The generator is on a dry surface.
- All loads are disconnected from the generator.
- The generator is properly grounded.
- Propane connection is secure with no leaks or damage.

DANGER



Never use the generator in a location that is wet or damp. Never expose the generator to rain, snow, water spray or standing water while in use. Protect the generator from all hazardous weather conditions. Moisture or ice can cause a short circuit or other malfunction in the electrical circuit.



Never operate the generator in an enclosed area. Engine exhaust contains carbon monoxide. Only operate the generator outside and away from windows, doors and vents.

NOTICE

The engine is equipped with a low oil shutdown switch. If the oil level becomes low, the engine may shut down and not start until the oil is filled to the proper level. Poor oil quality may interfere with the operation of the low oil shutdown switch.

The owner of the generator is responsible to ensure the proper oil level is maintained during the operation of the generator. Failure to maintain the proper oil level can result in engine damage.

NOTICE

When operating on LPG it is common for frost to form on the tank and regulators. This is not an indication of a problem. The amount of frost that forms can be affected by the size of the container, the amount of fuel being used, the humidity of the air and other operating conditions. In standard use this frost may reduce flow of gas and lower performance. If frost becomes an issue try exchanging fuel tanks to allow the first tank to warm up. You can also temporarily warm the tank up by pouring warm water over the top of the propane tank.

SWITCHING FUEL SOURCES

If you are switching fuel sources make sure to shut the generator down first and follow instructions on starting with your desired fuel source.

NOTICE

If you do not plan on operating the unit on propane do not leave the propane tank valve open. When starting on propane the engine may run rough for a few seconds while it purges gasoline in the carburetor.

OPERATION

POWER OUTPUT AND DEMAND

120-Volt AC devices have two different electric power demands that must be taken into consideration, namely the running power and the starting/peak power. Both are measured in Watts (typically abbreviated as “W”).

The steady state continuous load is the running power demand and this is often marked on the device near its model number or serial number. Sometimes the device might only be marked with its voltage (i.e. 120 V) and current draw (e.g. 6 Amp or 6 A), in which case the running power demand in Watts can be obtained by multiplying the voltage times the current, e.g. $120\text{ V} \times 20\text{ A} = 2,400\text{ W}$.

Simple resistive 120-Volt AC devices such as incandescent bulbs, toasters, heaters, etc. have no extra power demand when starting, and so their starting power demands are the same as their running power demands.

More complex 120-Volt AC devices containing inductive or capacitive elements such as electric motors have a momentary extra power demand when starting, which can be up to seven times the running power demand or more. Manufacturers of such devices rarely publish this starting power demand and so it's often necessary to estimate it. A rule of thumb for devices fitted with an electric motor is to apply a starting power multiplier of 1.2 for small hand-held or portable devices and a value of 3.5 for larger stationary devices. For example, a 900 W angle grinder can be assumed to have a starting power demand of at least $1.2 \times 900\text{ W}$, which equals 1,080 W. Similarly, a 1,650 W air compressor can be assumed to have a starting power demand of at least $3.5 \times 1,650\text{ W}$, which equals 5,775 W.

To prevent overloading of the generator's 120-Volt AC system:

1. Add up the running power demand of all the 120-Volt AC devices that will be connected to the generator at one time. This total must not be greater than the generator's specified running power output.
2. Add up the running power demand again, but for the largest motor-driven device use the value of its starting power demand instead of its running power demand. This total must not be greater than the generator's specified starting power output.
3. The total running power demand of all the devices that will be connected to any one of the generator's outlets must not exceed the generator's specified running power output or 3,700 W, whichever is the lesser.

OPERATION

STARTING THE GENERATOR ON GAS

1. Move generator to a flat surface outside in a well ventilated area.
2. Check oil levels.
3. Verify the battery is connected and both battery cables are attached to their corresponding polarity.
4. Disconnect all electrical loads from the generator.
5. Confirm there is gas in the tank.
6. Make sure the circuit breakers are properly set (see Figure 7 below).

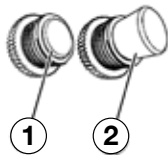

Figure 7 - Breakers - (1) Operating Position
(2) Tripped Position

7. Move the fuel shut off valve to the **ON** position (see Figure 8 below).

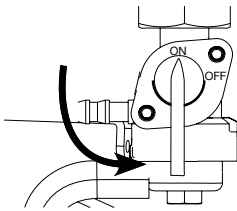

Figure 8 - Fuel Shut Off - ON

8. Move the fuel selector switch to Gasoline (see Figure 9).

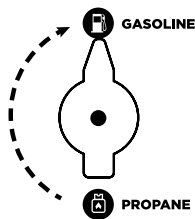

Figure 9 - Fuel Selector - Gasoline

9. Move the choke lever to the **ON** position (see Figure 10 below).

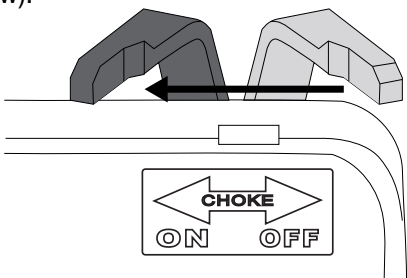

Figure 10 - Choke Lever - ON

10. Choose starting method:

- Electric Start:** Push and hold the engine control switch in the **START** position until the engine starts. Once the engine starts, release the engine control switch; the switch will automatically move into the **RUN** position (see Figure 11 below).

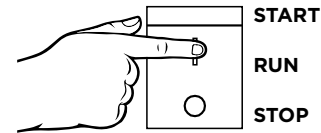

Figure 11 - Engine Control Switch - START

NOTICE

Failure to release the engine control switch once the engine starts could result in damage to the generator.

Never push the engine control switch to the **START** position while the engine is running' this could damage the generator.

Note: If the engine fails to start after 5 seconds, release the engine control switch. Let the generator sit idle for 15 seconds and then repeat step 10a. If the cranking speed drops after each unsuccessful attempt, then the battery may not be adequately charged. Manually start the generator in step 10b.

- Manual Start:** Make sure the engine control switch is in the **RUN** position. Firmly grasp and pull the recoil handle slowly until you feel increased resistance. At this point, apply a rapid pull while pulling up and slightly away from the generator (see Figure 12).



Figure 12 - Engine Control Switch - RUN
Recoil Handle - PULL

10. As the engine starts and stabilizes, gradually move the choke lever back to the **OFF** position (see Figure 13 below).

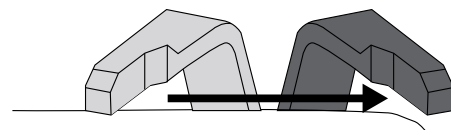

Figure 13 - Choke Lever - OFF

OPERATION

STARTING THE GENERATOR ON PROPANE

1. Move generator to a flat surface outside in a well ventilated area.
2. Check oil levels.
3. Verify the battery is connected and both battery cables are attached to their corresponding polarity.
4. Disconnect all electrical loads from the generator.
5. Make sure the circuit breakers are properly set (see Figure 7).
6. Move the fuel shut off valve to the **OFF** position (see Figure 14 below).

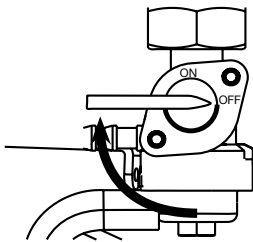

Figure 14 - Fuel Shut Off - OFF

7. Switch fuel selector on control panel to Propane.
8. Move the choke to the OFF position (see Figure 15).

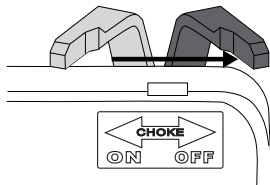

Figure 15 - Choke - OFF

9. Make sure LPG hose is safely secured from generator to tank and tank valve is open (see Figure 16).

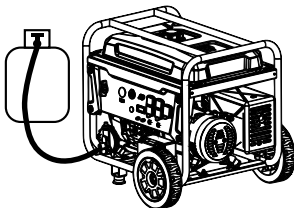

Figure 16 - Connect Propane Tank

10. Choose starting method.

- a. **Electric Start:** Push and hold the engine control switch in the **START** position until the engine starts. Once the engine starts, release the engine control switch; the switch will automatically move into the **RUN** position (see Figure 11).

NOTICE

Failure to release the engine control switch once the engine starts could result in damage to the generator.

Never push the engine control switch to the **START** position while the engine is running; this could damage the generator.

Note: If the engine fails to start after 5 seconds, release the engine control switch. Let the generator sit idle for 15 seconds and then repeat step 10a. If the cranking speed drops after each unsuccessful attempt, then the battery may not be adequately charged. Manually start the generator in step 10b.

- b. **Manual Start:** Make sure the engine control switch is in the **RUN** position. Firmly grasp and pull the recoil handle slowly until you feel increased resistance. At this point, apply a rapid pull while pulling up and slightly away from the generator (see Figure 12).



OPERATION

STOPPING THE GENERATOR

Normal Operation

During normal operation, use the following steps to stop your generator:

1. Remove any connected loads from the control panel receptacles.
2. Allow the generator to run at “no load” to reduce and stabilize engine and alternator temperatures.
3. Position the engine control switch to **STOP** (see figure 17). If you plan to store the generator after use, turn the fuel shutoff valve to the **OFF** position and allow the fuel to be consumed from the carburetor.
4. If running on propane, make sure to close valve on propane tank.

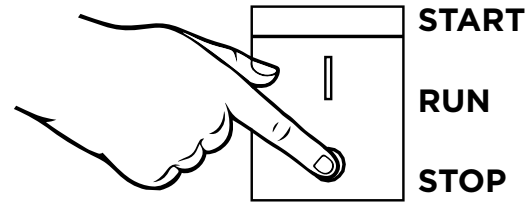

Figure 17 - Move engine switch to STOP

During an Emergency

If there is an emergency and the generator must be stopped quickly, position the engine control switch to the **STOP** position immediately.

MAINTENANCE



BEFORE PERFORMING MAINTENANCE ON THE GENERATOR, REVIEW THE SAFETY SECTION STARTING ON PAGE 5, AS WELL AS THE FOLLOWING SAFETY MESSAGES.

⚠ WARNING



Avoid accidentally starting the generator during maintenance by removing the spark plug boot from the spark plug. For electric start generators, also disconnect the battery cables from the battery (disconnect the black negative (-) cable first) and place the cables away from the battery posts to avoid arcing.



Allow hot components to cool to the touch prior to performing any maintenance procedure.

⚠ WARNING



Internal pressure can build in the engine crankcase while the engine is running. Removing the oil fill plug/dipstick while the engine is hot can cause extremely hot oil to spray out of the crankcase and can severely burn skin. Allow engine oil to cool for several minutes before removing the oil fill plug/dipstick.



Always perform maintenance in a well-ventilated area. Gasoline fuel and fuel vapors are extremely flammable and can ignite under certain conditions.

MAINTENANCE

MAINTENANCE SCHEDULE

⚠ WARNING



Failure to perform periodic maintenance or not following maintenance procedures can cause the generator to malfunction and could result in death or serious injury.

NOTICE

Periodic maintenance intervals vary depending on generator operating conditions. Operating the generator under severe conditions, such as sustained high-load, high-temperature, or unusually wet or dusty environments, will require more frequent periodic maintenance. The intervals listed in the maintenance schedule should be treated only as a general guideline.

⚠ CAUTION



Avoid skin contact with engine oil or gasoline. Prolonged skin contact with engine oil or gasoline can be harmful. Frequent and prolonged contact with engine oil may cause skin cancer. Take protective measures and wear protective clothing and equipment. Wash all exposed skin with soap and water.

Following the maintenance schedule is important to keep the generator in good operating condition. The following is a summary of maintenance items by periodic maintenance intervals.

TABLE 1: MAINTENANCE SCHEDULE - OWNER PERFORMED

| Maintenance Item | Before Every Use | After First 20 Hours or First Month of Use | After 50 Hours of Use or Every 6 Months | After 100 Hour of Use or Every 6 Months | After 300 Hours of Use or Every Year |
|-------------------------|------------------|--------------------------------------------|-----------------------------------------|-----------------------------------------|--------------------------------------|
| Engine Oil | Check Level | Change | Change | - | - |
| Cooling Features | Check/Clean | - | - | - | - |
| Air Filter | Check | - | Clean* | - | Replace |
| Spark Plug | - | - | - | Check/Clean | Replace |
| Spark Arrestor | - | - | - | Check/Clean | - |

*Service more frequently if operating in dry and dusty conditions

TABLE 2: MAINTENANCE SCHEDULE - AUTHORIZED WESTINGHOUSE SERVICE DEALER PERFORMED

| Maintenance Item | Before Every Use | After First 20 Hours or First Month of Use | After 50 Hours of Use or Every 6 Months | After 100 Hour of Use or Every 6 Months | After 300 Hours of Use or Every Year |
|------------------------|------------------|--------------------------------------------|-----------------------------------------|-----------------------------------------|--------------------------------------|
| Valve Clearance | - | - | - | - | Check/Adjust |
| Fuel Filter | - | - | - | Check/Clean | - |

MAINTENANCE

DATA CENTER
VOLTS | FREQUENCY | HOURS

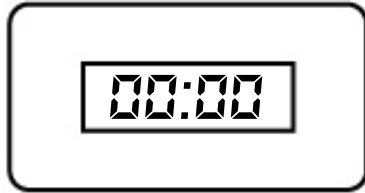

MAINTENANCE REMINDERS

The VFT meter on this unit has programmed maintenance reminders. When the VFT meter shows:

P 0 2 5 This is to remind you to change the oil after the initial 25 hours of run time.

P 0 5 0 It is time to clean the air filter.

P 1 0 0 It is time change/clean the fuel filter, clean the air filter, and change the oil.

CLEANING THE SPARK ARRESTOR

⚠ WARNING



Hot Surfaces. When operating machine, do not touch hot surfaces. Keep machine away from combustibles during use. Hot surfaces could result in severe burns or fire.

Check and clean the spark arrestor after every 100 hours of use or 6 months.

1. Generator must be cold to perform this maintenance.
2. Move the inverter to a flat, level surface.
3. Remove the 6 screws holding the muffler cover in place (see Figure 18).

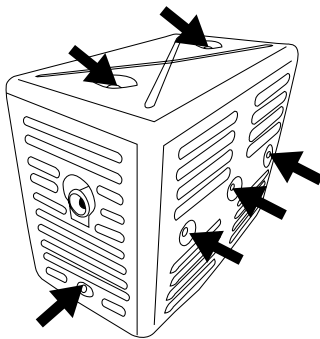

Figure 18: Remove screws holding muffler cover

4. Once the cover is removed, locate the screw on the tip of the muffler and remove. Pull the spark arrestor out of the muffler. (see Figure 19).

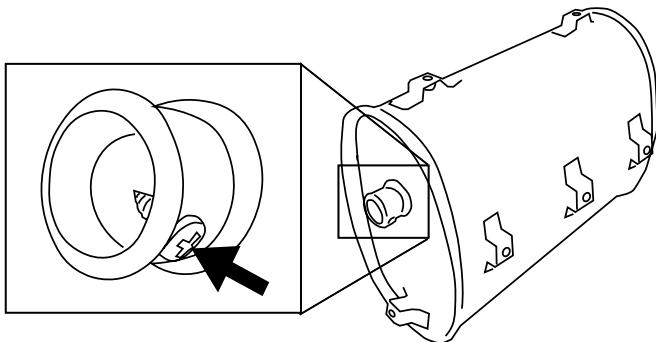

Figure 19: Remove spark arrestor

5. If the spark arrestor screen shows signs of wear (rips, tears or large openings in the screen), replace the spark arrestor screen. **NOTE:** Only use Westinghouse spark arrestors as replacements.
6. If screen is not torn then clean using a wire brush, commercial solvent, or compressed air. Remove any dirt and debris that may have collected on the spark arrestor screen (see Figure 20).

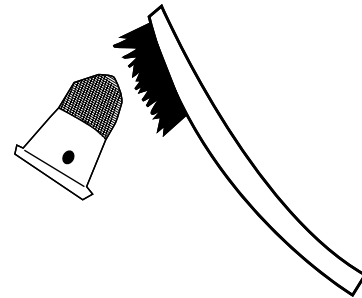
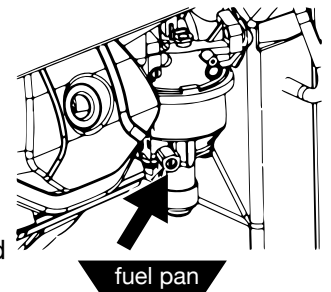

Figure 20: Clean spark arrestor

7. Install the spark arrestor back into the muffler. Make sure to fully push it in so that it is tight on the tip of the muffler.
8. Replace the muffler cover and tighten all 6 screws.

DRAINING CARBURETOR FLOAT BOWL

1. Make sure the generator is off and you are away from any open flames.
2. Place pan (or suitable container) under the carburetor assembly.
3. Loosen screw at bottom of the bowl and allow gas to drain out.
4. After all the gas has drained out, tighten the screw.



MAINTENANCE

ENGINE OIL MAINTENANCE

Engine Oil Specification

1. Only use the engine oil specified in Figure 21.
2. Only use 4-stroke/cycle engine oil. **NEVER USE 2-STROKE/CYCLE OIL.** Synthetic oil is an acceptable substitute for conventional oil.

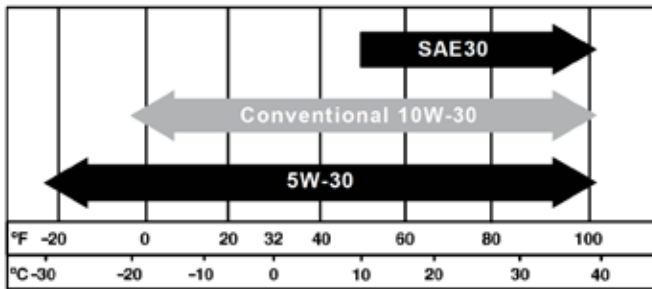

Figure 21 - Recommended Oil

CHECKING ENGINE OIL

NOTICE

Always maintain proper engine oil level. Failure to maintain proper engine oil level could result in severe damage to the engine and/or shorten the life of the engine. Always use the specified engine oil. Failure to use the specified engine oil can cause accelerated wear and/or shorten the life of the engine.

Engine oil level should be checked before every use.

1. Always operate or maintain the generator on a flat surface.
2. Stop engine if running.
3. Let engine sit and cool for several minutes (allow crankcase pressure to equalize).
4. With a damp rag, clean around the oil fill plug/dipstick.
5. Remove oil fill plug/dipstick (see Figure 22 below).

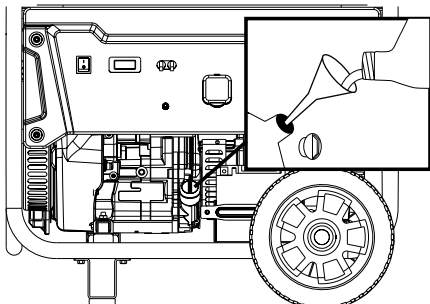

Figure 22 - Oil Fill Plug/Dipstick

6. Check oil level: When checking the engine oil, remove the oil fill plug/dipstick and wipe it clean. Thread the oil fill plug/dipstick all the way back in and then remove and check the oil level on the oil fill plug/dipstick.

- **Acceptable Oil Level** – Oil is visible on the crosshatches between the H and L lines on the oil fill plug/dipstick (see Figure 20).
- **Low Oil** – Oil is below the L line on the oil fill plug/dipstick.

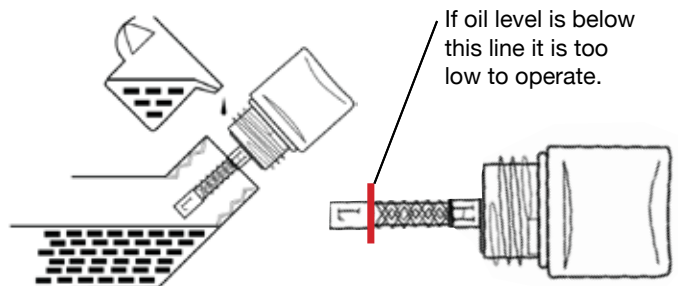

Figure 23 - Checking Oil Level

ADDING ENGINE OIL

1. Always operate or maintain the generator on a flat surface.
2. Stop engine if running.
3. Let engine sit and cool for several minutes (allow crankcase pressure to equalize).
4. Thoroughly clean around the oil fill plug/dipstick.
5. Remove oil fill plug/dipstick and wipe clean.
6. Select the proper engine oil as specified in Figure 21.
7. Using the supplied funnel and tube, slowly add engine oil to the engine. Stop frequently to check the level to avoid overfilling.
8. Continue to add oil until the oil is at the correct level (see Figure 23).

MAINTENANCE

CHANGING ENGINE OIL

1. Stop the engine.
2. Let engine sit and cool for several minutes (allow crankcase pressure to equalize).
3. Place oil pan (or suitable container) under the oil drain plug (see Figure 24).
4. With a damp rag, thoroughly clean around the oil drain plug.
5. Remove the oil drain plug (see Figure 24). Once removed, place the oil drain plug on a clean surface.

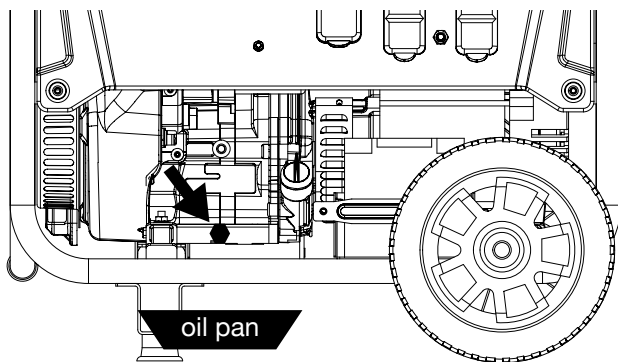

Figure 24 - Oil Drain Plug

6. Allow oil to completely drain.
7. Replace oil drain plug.
8. Fill crankcase with oil following the steps outlined in *Adding Engine Oil*.

NOTICE

Never dispose of used engine oil by dumping the oil into a sewer, on the ground, or into ground water or waterways. Always be environmentally responsible. Follow the guidelines of the EPA or other governmental agencies for proper disposal of hazardous materials. Consult local authorities or reclamation facility.

AIR FILTER MAINTENANCE

⚠ WARNING



Never use gasoline or other flammable solvents to clean the air filter. Use only household detergent soap to clean the air filter.

Cleaning the Air Filter

The air filter must be cleaned after every 50 hours of use or 3 months (frequency should be increased if generator is operated in a dusty environment).

1. Turn off the generator and let it cool for several minutes if running.
2. Move the generator to a flat, level surface.
3. Unclip the clips on the top and bottom of the air filter cover (Figure 25).

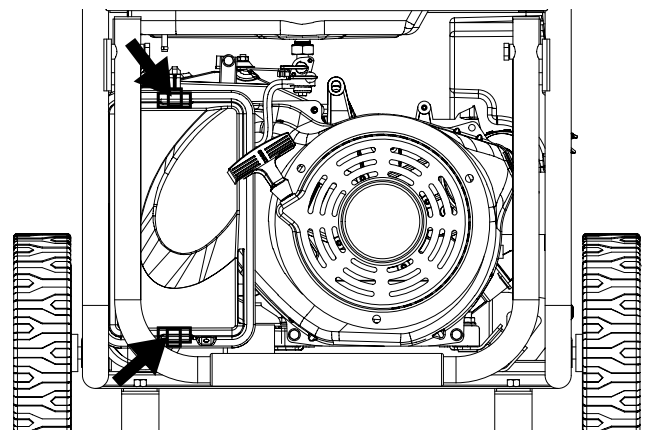

Figure 25 - Clips on air filter

4. Remove the black coarse air filters.
5. Wash the foam air filter elements by submerging the elements in a solution of household detergent soap and warm water. Slowly squeeze the foam to thoroughly clean.

NOTICE

NEVER twist or tear the foam air filter element during cleaning or drying. Only apply slow but firm squeezing action.

6. Rinse in clean water by submerging the air filter elements in fresh water and applying a slow squeezing action

MAINTENANCE

Cleaning the Air Filter - Continued

NOTICE

Never dispose of soap cleaning solution used to clean the air filter by dumping the solution into a sewer, on the ground, or into ground water or waterways. Always be environmentally responsible. Follow the guidelines of the EPA or other governmental agencies for proper disposal of hazardous materials. Consult local authorities or reclamation facility.

7. Dispose of used soap cleaning solution properly.
8. Dry the air filter elements by again applying a slow firm squeezing action.
9. Once the air filters are dry, coat the air filters with clean engine oil (see Figure 26 below).



Figure 26

10. Squeeze the filters to remove any excess oil.
11. Install the filters back into the unit. If there are two filters make sure the gray (fine) air filter goes in first followed by the black (coarse) air filter on the outside.
12. Install the air filter cover and secure the air filter assembly.

SPARK PLUG MAINTENANCE

The spark plug must be checked and cleaned after every 100 hours of use or 6 months and must be replaced after 300 hours of use or every year.

1. Stop the generator and let it cool for several minutes if running.
2. Move the generator to a flat, level surface.
3. Remove the spark plug boot by firmly pulling the plastic spark plug boot handle directly away from the engine (see Figure 27).

NOTICE

Never apply any side load or move the spark plug laterally when removing the spark plug. Applying a side load or moving the spark plug laterally may crack and damage the spark plug boot.

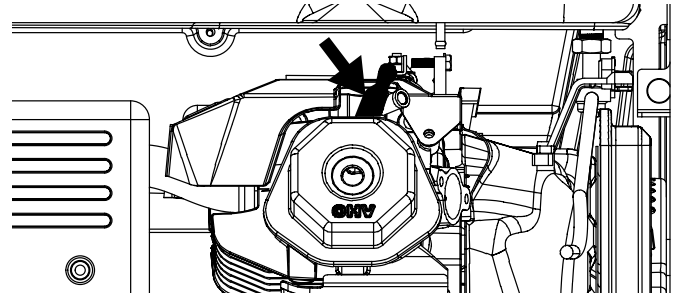

Figure 27 - Remove Spark Plug Boot

4. Clean area around the spark plug.
 5. Using the 13/16" spark plug socket wrench provided, remove the spark plug from the cylinder head.
 6. Place a clean rag over the opening created by the removal of the spark plug to make sure no dirt can get into the combustion chamber.
- Inspect the spark plug for:
 - Cracked or chipped insulator
 - Excessive wear
 - Spark plug gap (the acceptable limit of 0.027–0.032 in. [0.70 – 0.80 mm]) (see Figure 28).

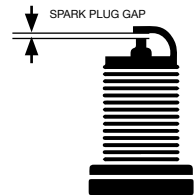

Figure 28

NOTICE

Use only recommended spark plugs when servicing. The manufacturer is not responsible for engine damage when using spark plugs not recommended by the manufacturer.

7. Install the spark plug by carefully following the steps outlined below:
 - a. Carefully insert the spark plug back into the cylinder head. Hand-thread the spark plug until it bottoms out.
 - b. Using the 13/16" spark plug socket wrench provided, turn the spark plug to ensure it is fully seated.
 - c. Replace the spark plug boot, making sure the boot fully engages the spark plug's tip.

Recommended Spark Plug Replacement:

NGK: (1034) BP7ES (Replacement)

Torch: F7TC (OE Spark Plug)

Westinghouse Part Number: 180526

MAINTENANCE

CHECKING AND ADJUSTING VALVE LASH

⚠ CAUTION

 Checking and adjusting valve lash must be done when the engine is cold.

1. Remove the rocker arm cover and carefully remove the gasket. If the gasket is torn or damaged, it must be replaced.
2. Remove the spark plug so the engine can be rotated more easily.
3. Rotate the engine to top dead center (TDC) of the compression stroke. Looking through the spark plug hole, the piston should be at the top.
4. Both the rocker arms should be loose at TDC on the compression stroke. If they are not, rotate the engine 360°.
5. Insert a feeler gauge between the rocker arm and the push rod and check for clearance (see Figure 29). See Table 1 for valve lash specifications

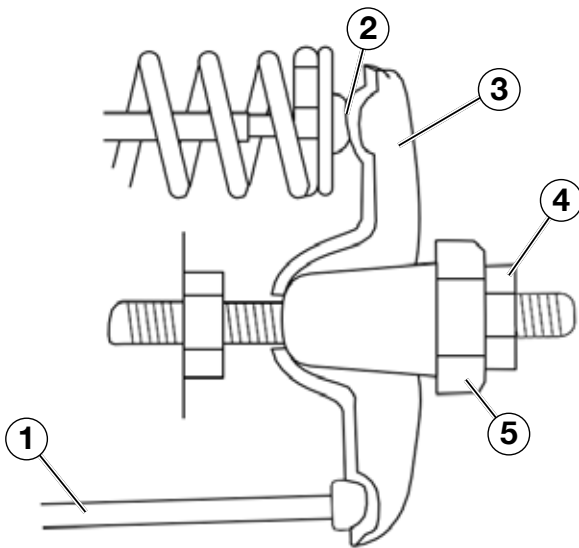

Figure 20
 (1) Push Rod, (2) Feeler Gauge Area
 (3) Rocker Arm, (4) Jam Nut, (5) Adjusting Nut

(Table 1) Standard Valve Lash

| | Intake Valve | Exhaust Valve |
|--------------------|----------------------------------------|----------------------------------------|
| Valve Lash | 0.0035 ± 0.0043 in (0.09 ± 0.11 mm) | 0.0043 ± 0.0051 in (0.11 ± 0.13 mm) |
| Bolt Torque | 8-12N.m | 8-12N.m |

6. If an adjustment is required, hold the adjusting nut and loosen the jam nut.

TESTING GFCI OUTLETS

1. Start the generator and allow it to warm up.
2. Press the test button on the GFCI outlet.
3. The reset button should pop out and there will be no power from the outlets. If the reset button does not pop out, the GFCI outlet is not working correctly and must be repaired before the generator can be operated.
4. Press the reset button to restore power to the outlet.

BATTERY REPLACEMENT

1. Remove the spark plug wire from spark plug.
2. Remove the battery quick connect plugs.
3. Loosen and remove the bolt on the battery hold-down plate and swing the plate out.
4. Tip the battery forward slightly to access battery cables.
5. Disconnect the black negative (-) battery cable from the battery first.
6. Disconnect the red positive (+) battery cable second and remove the battery.

NOTICE

Dispose of the used battery properly according to the guidelines established by your local or state government.

7. Install the new battery into the generator frame.
8. Connect the red positive (+) battery cable to the battery first.
9. Connect the black negative (-) battery cable to the battery second. Then connect the battery quick connect plugs.
10. Install the battery hold-down plate using the nuts removed in step 2.
11. Install the spark plug wire onto spark plug.

See below for the battery specification when replacing the battery.

| | |
|----------------------------|----------------------------|
| Westinghouse Part No. | 100557 |
| After Market Battery Model | YT9A |
| Volts | 12 |
| Amp Hr | 9 |
| Dimensions | 5 5/16in by 3in by 5 3/8in |

MAINTENANCE

CLEANING THE GENERATOR

It is important to inspect and clean the generator before every use.

Clean All Engine Air Inlet and Outlet Ports – Make sure all engine air inlet and outlet ports are clean of any dirt and debris to ensure the engine does not run hot.

Clean All Engine Cooling Fins – Use a damp rag and a brush to loosen and remove all dirt on or around the engine's cooling fins.

Clean All Alternator Cooling Air Inlets and Exhaust Ports – Make sure the cooling air inlets and exhaust ports of the alternator are free of any debris and obstructions. Use a vacuum cleaner to remove dirt and debris stuck in the cooling air inlets and exhaust ports.

General Cleaning of the Generator – Use a damp rag to clean all remaining surfaces.

STORAGE

STORING GENERATOR

WARNING



Never store a generator with fuel in the tank indoors or in a poorly ventilated area where the fumes can come in contact with an ignition source such as a: 1) pilot light of a stove, water heater, clothes dryer or any other gas appliance; or 2) spark from an electric appliance.

NOTICE

Gasoline stored for as little as 60 days can go bad, causing gum, varnish and corrosive buildup in fuel lines, fuel passages and the engine. This corrosive buildup restricts the flow of fuel, preventing an engine from starting after a prolonged storage period.

Proper care should be taken to prepare the generator for any storage.

1. Make sure the Engine Switch is switched to **STOP**.
2. Disconnect the battery.
3. Clean the generator as outlined in *Cleaning the Generator*.
4. Drain all gasoline from the fuel tank as best as possible.
5. With the fuel shut off valve open, start the engine and allow the generator to run until all the remaining gasoline in the fuel lines and carburetor is consumed and the engine shuts off.
6. Close the fuel shut off valve.
7. Change the oil (see *Changing Engine Oil*).
8. Remove the spark plug (see *Spark Plug Maintenance*) and place about 1 tablespoon of oil in the spark plug opening. While placing a clean rag over the spark plug opening, slowly pull there coil handle to allow the engine to turn over several times. This will distribute the oil and protect the cylinder wall from corroding during storage.
9. Replace the spark plug (see *Spark Plug Maintenance*).
10. Move the generator to a clean, dry place for storage.

TROUBLESHOOTING

⚠ WARNING



Before attempting to service or troubleshoot the generator, the owner or service technician must first read the owner's manual and understand and follow all safety instructions. Failure to follow all instructions may result in conditions that can lead to voiding of the EPA certification or product warranty, serious personal injury, property damage or even death.

| PROBLEM | POTENTIAL CAUSE | SOLUTION |
|----------------------------------------------------------------|----------------------------------------------------------------------------------------------------|--------------------------------------------------------------------------------------------------------------------------------------------------------------------------|
| Engine is running, but no electrical output | 1. Circuit breakers are tripped. | 1. Reset the circuit breakers and check for overload condition. |
| | 2. The power cord's plug connector is not fully engaged in the generator's outlet. | 2. Verify plug connector is firmly engaged in the generator's outlet. If using the 240V outlet, make sure plug connector is rotated 1/4 turn in the clockwise direction. |
| | 3. Faulty or defective power cord | 3. Replace power cord. |
| | 4. Faulty or defective electrical appliance | 4. Try connecting a known good appliance to verify the generator is producing electrical power. |
| | 5. GFCI outlet is tripped | 5. Press the reset button on the GFCI outlet. |
| | 6. If trying 1-5 above does not solve the problem, the cause might be the generator has a fault. | 6. Take the generator to your nearest authorized service dealer. |
| Engine will not start or remain running while trying to start. | 1. Fuel shutoff valve is in the OFF position. | 1. Move the fuel shut off valve to the ON position. |
| | 2. Generator is out of gasoline. | 2. Add gasoline to the generator. |
| | 3. Fuel flow is obstructed. | 3. Inspect and clean fuel delivery passages. |
| | 4. Unit is over choked. | 4. Move the choke lever halfway between the ON and OFF positions. |
| | 5. Starting battery may have insufficient charge | 5. On electric start models only. Check battery output and charge battery as necessary. |
| | 6. Dirty air filter | 6. Check and clean the air filter. |
| | 7. Low oil level shut down switch is preventing the unit from starting. | 7. Check oil level and add oil if necessary. |
| | 8. Spark plug boot is not fully engaged with the spark plug tip. | 8. Firmly push down on the spark plug boot to ensure the boot is fully engaged |
| | 9. Spark plug is faulty. | 9. Remove and check the spark plug. Replace if faulty. |
| | 10. Dirty/plugged spark arrestor | 10. Check and clean the spark arrestor. |
| | 11. Stale fuel | 11. Drain fuel and replace with fresh fuel. |
| | 12. If trying 1-11 above does not solve the problem, the cause might be the generator has a fault. | 12. Take the generator to your nearest authorized service dealer. |
| Generator suddenly stops running. | 1. Generator is out of fuel. | 1. Check fuel level. Add fuel if necessary. |
| | 2. The low oil shut down switch has stopped the engine. | 2. Check oil level and add oil if necessary. |
| | 3. Too much load | 3. Restart the generator and reduce the load. |
| | 4. If trying 1-3 above does not solve the problem, the cause might be a fault in the generator. | 4. Take the generator to your nearest authorized service dealer. |
| Engine runs erratic; does not hold a steady RPM. | 1. Choke was left in the ON position. | 1. Move choke to the OFF position |
| | 2. Dirty air filter | 2. Clean the air filter. |
| | 3. Applied loads maybe cycling on and off | 3. As applied loads cycle, changes in engine speed may occur; this is a normal condition. |
| | 4. If trying 1-3 above does not solve the problem, the cause might be a fault in the generator | 4. Take the generator to your nearest authorized service dealer. |

WH1000DF EXPLODED VIEW

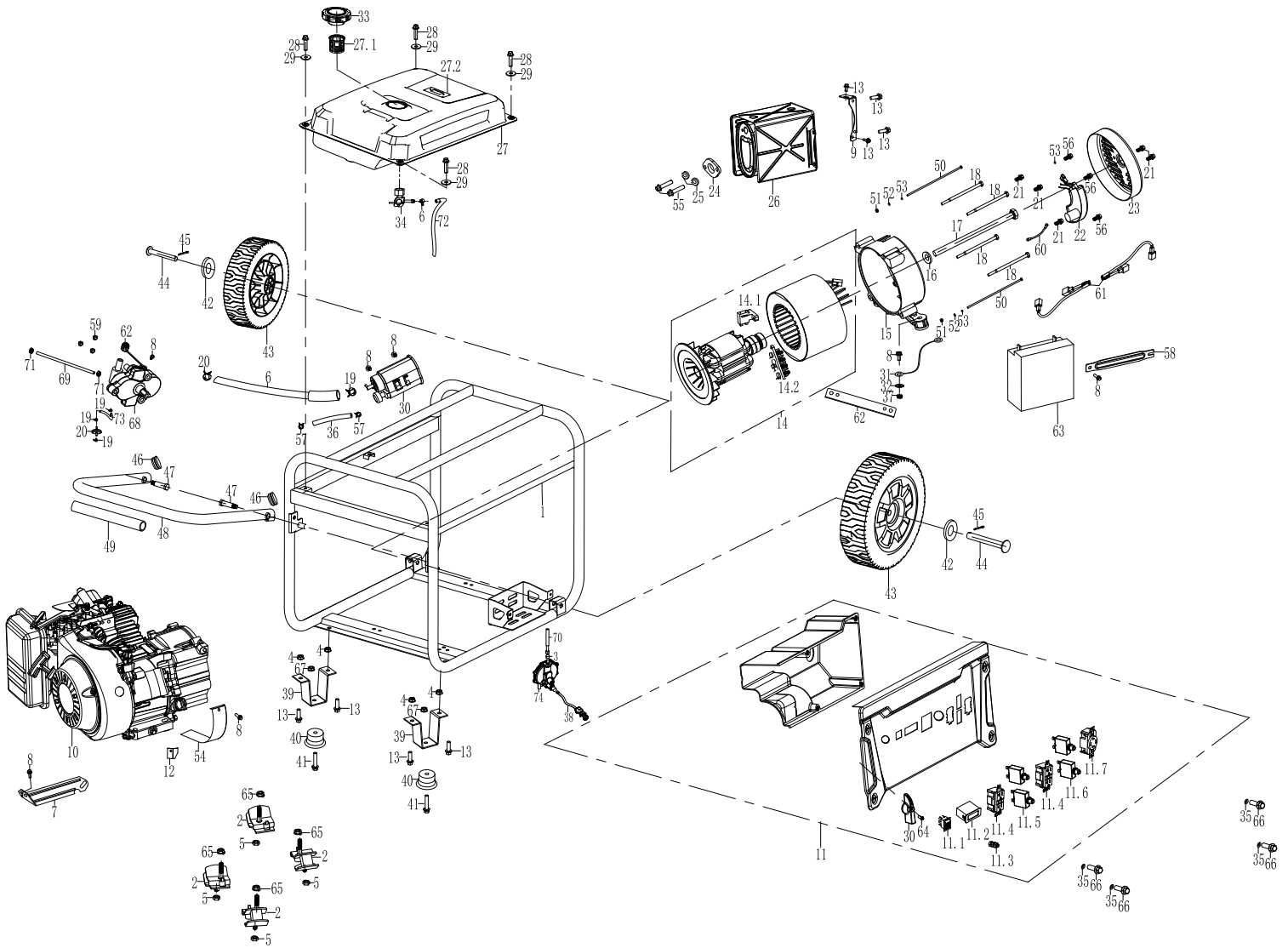

| NO. | PART. | DESCRIPTION |
|------|--------|----------------------|
| 1 | NA | FRAME |
| 2 | NA | ISOLATOR |
| 3 | NA | METAL CAP |
| 4 | 100520 | NUT M8 |
| 5 | 180524 | NUT M8 |
| 6 | 140508 | CLIP, FUEL LINE Φ7.5 |
| 7 | 180563 | BRACKET,AIR CLEANER |
| 8 | 120505 | BOLT M6X12 |
| 9 | 110504 | MUFFLER BRACKET |
| 10 | 300837 | ENGINE ASSY |
| 11 | 300836 | PANEL COMP |
| 11.1 | 130542 | ON/OFF/RUN SWITCH |
| 11.2 | 130158 | VFT METER |

| NO. | PART. | DESCRIPTION |
|------|--------|-----------------------------------|
| 11.3 | 300674 | GROUND TERMINAL ASSEMBLY |
| 11.4 | 130512 | DOUBLE SOCKET. 5-20R/UL |
| 11.5 | 130564 | THERMAL PROTECTOR 20A |
| 11.6 | 300838 | THERMAL PROTECTOR 33A |
| 11.7 | 130505 | L14-30 RECEPTACLE |
| 12 | 180562 | DUSTPROOF SHEET |
| 13 | 100516 | BOLT M8X16 |
| 14 | 120501 | ALTERNATOR ASSY |
| 14.1 | 130533 | CARBON BRUSH ASSEMBLY |
| 14.2 | 120503 | GROUNDING POST COMP. |
| 15 | 120504 | MOTOR STAND |
| 16 | 100540 | GASKET, ROTOR BOLT Φ10.5×Φ30×4 |

WH1000DF EXPLODED VIEW PART NO.

| NO. | PART. | DESCRIPTION |
|------|---------|--------------------------------------------------|
| 17 | 120514 | BOLT M10X1.25X283 |
| 18 | 120513 | BOLT M6X200 |
| 19 | 300115 | CLIP, FUEL LINE Φ9.5 |
| 20 | 15053 | FILTER,FUEL |
| 21 | 120537 | BOLT M5X12 |
| 22 | 120517A | AUTOMATIC VOLTAGE REGULATOR |
| 23 | 120519 | END COVER,GENERATOR |
| 24 | 110501 | GASKET, EXHAUST PIPE |
| 25 | 110502 | SPRING WASHER Φ8 |
| 26 | 110500 | MUFFLER COMP |
| 27 | 150500 | FUEL TANK ASSEMBLY |
| 27.1 | 150529 | FUEL STRAINER |
| 27.2 | 230514 | FUEL GAUGE |
| 28 | 120541 | BOLT M6X25 |
| 29 | 150501 | WASHER FUEL TANK |
| 30 | 150512 | CARBON TANK COMP |
| 31 | 120542 | FRAME WIRE |
| 32 | NA | TOOTH TYPE GASKET Φ8 |
| 33 | 150505 | FUEL TANK CAP COMP |
| 34 | 150552 | FUEL COCK |
| 35 | 100547 | WASHER |
| 36 | 160513 | THE CARBON TANK IS CONNECTED WITH THE AIR FILTER |
| 37 | 100548 | NUT M6 |
| 38 | 100594 | VALVE |
| 39 | 100512 | FOOT BRACKET |
| 40 | 100515 | VIBRATION ISOLATION PAD, SQUARE |
| 41 | 100582 | BOLT M6X28 |
| 42 | 100510 | FLAT WASHER Φ13XΦ37X4 |
| 43 | 100506 | WHEEL |
| 44 | 190311 | AXLE |
| 45 | 100508 | COTTER PIN |
| 46 | 100527 | PLUG, HANDLE |
| 47 | 100525 | BOLT, HANDLE M10XΦ12.5X53.5 |
| 48 | 100521 | HANDLE ASSEMBLY |
| 49 | 100523 | RUBBER, HANDLE |
| 50 | 120509 | BOLT M5X230 |
| 51 | 120510 | NUT M5 |
| 52 | 120511 | FLAT WASHER Φ5 |

| NO. | PART. | DESCRIPTION |
|-----|--------|---------------------------------|
| 53 | 120512 | SPRING WASHER Φ5 |
| 54 | 180561 | GUARD COVER, CRANKCASE |
| 55 | 110503 | BOLT M8X30 |
| 56 | 120518 | BOLT M5X16 |
| 57 | NA | CLIP, FUEL LINE Φ8 |
| 58 | 100558 | BATTERY HOLDER |
| 59 | NA | NUT M5 |
| 60 | 120516 | GROUNDING WIRE |
| 61 | 300839 | BATTERY CABLE KIT |
| 62 | 100595 | COVER, LPG REGULATOR |
| 63 | 100557 | BATTERY |
| 64 | 130535 | HEXAGON PATTERN PAN HEAD SCREWS |
| 65 | 100551 | NUT M10 |
| 66 | 130536 | BOLT M6X16 |
| 67 | NA | LOCK NUT M6 |
| 68 | 130538 | FUEL SELECTOR SWITCH |
| 69 | 100586 | LOW PRESSURE PIPE FROM SWITCH |
| 70 | 100587 | LOW PRESSURE PIPE SHORT |
| 71 | NA | CLIP Φ12 |
| 72 | 100589 | FUEL HOSE FROM FUEL COCK |
| 73 | 100590 | FUEL HOSE |
| 74 | 100596 | RELIEF VALVE ASSEMBLY |
| NA | 230523 | 1.1L OIL BOTTLE |
| NA | 10003 | WH1000DF Owners Manual |

| Westinghouse Generator Accessories (call to order) | |
|----------------------------------------------------|---------------------------------------------------------|
| 210004 | GENERATOR COVER |
| 3013425C | 25' GENERATOR CORD: 30A 120V TT-30P TO TT-30R |
| 3013450C | 50' GENERATOR CORD: 30A 120V TT-30P TO TT-30R |
| 3015425C | 25' GENERATOR CORD: 30A 120V L5-30P TO TT-30R |
| 30151425C | 25' GENERATOR CORD: 30A 120V L5-30P TO (3X) 5-20R |
| 3021225C | 25' GENERATOR CORD: 30A 120V L14-30P TO L14-30R |
| 3021250C | 50' GENERATOR CORD: 30A 120V L14-30P TO L14-30R |
| 5027825C | 25' GENERATOR CORD: 50A 120/240V 14-50P TO 14-50R |
| 5027850C | 50' GENERATOR CORD: 50A 120/240V 14-50P TO 14-50R |
| 30211625C | 25' GENERATOR CORD: 30A 120V L14-30P TO (4X) 5-20R |
| 30211650C | 50' GENERATOR CORD: 30A 120V L14-30P TO (4X) 5-20R |
| 30114A | GENERATOR PLUG ADAPTER: 30A 120V L14-30P TO TT-30R |
| 50218A | GENERATOR PLUG ADAPTER: 50A 120/240V L14-30P TO 14-50RR |
| 302116A | GENERATOR PLUG ADAPTER: 30A 120V L14-30P TO (4X) 5-20R |
| 30154A | GENERATOR PLUG ADAPTER: 30A 120V L5-30P TO TT-30R |
| 30136A | GENERATOR PLUG ADAPTER: 30A 120V TT-30P TO L5-30R |
| 301514A | GENERATOR PLUG ADAPTER: 30A 120V L5-30P TO (3X) 5-20R |
| 30194A | GENERATOR PLUG ADAPTER: 30A 120V 5-20P TO TT-30R |
| 30196A | GENERATOR PLUG ADAPTER: 30A 120V 5-20P TO L5-30R |
| 50158A | GENERATOR PLUG ADAPTER: 30A 120V L5-30P TO 14-50R |
| 50138A | GENERATOR PLUG ADAPTER: 30A 120V TT-30P TO 14-50R |

WH1000DF ENGINE VIEW

| NO. | PART. | DESCRIPTION |
|-----|--------|------------------------------|
| 1 | 190223 | THE CRANKSHAFT BOX BODY |
| 2 | 180593 | BEARING |
| 3 | 180504 | THE CRANKSHAFT OIL SEAL |
| 4 | 190412 | PENDULUM STEM SEAL |
| 5 | 190410 | SWINGING ROD |
| 6 | 190409 | SWINGING ROD GASKET |
| 7 | 190408 | CHECK BACK CLIP |
| 8 | 180507 | OIL DRAIN BOLT |
| 9 | 180508 | OIL DRAIN BOLT WASHER |
| 10 | 180586 | OIL SENSOR |
| 11 | 130536 | BOLT WITH DISC M6X16 |
| 12 | 180604 | POSITIONING PIN OF CRANKCASE |
| 13 | 190407 | THE PISTON |

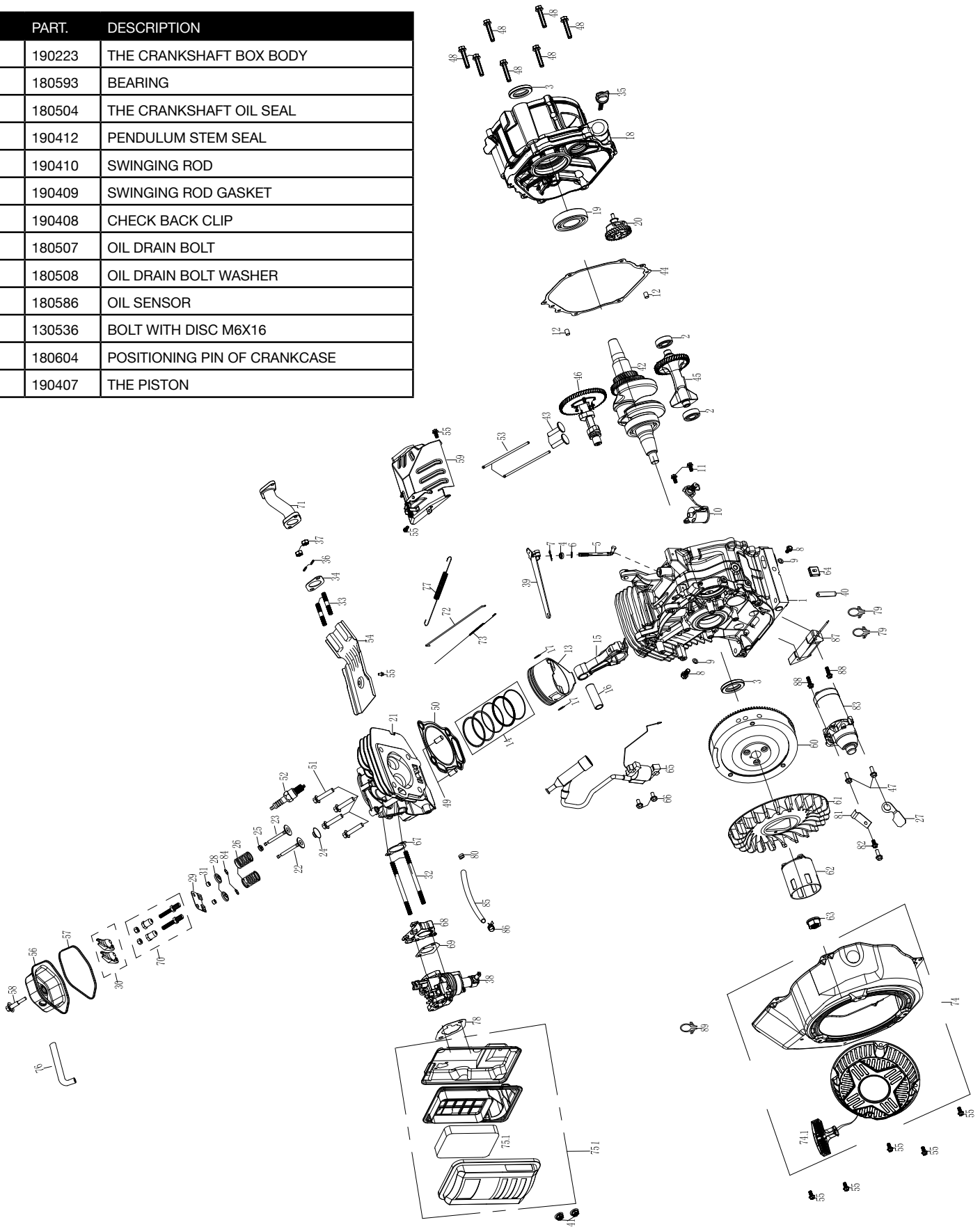

WH1000DF ENGINE PART NO.

| NO. | PART. | DESCRIPTION |
|-----|--------|------------------------------------|
| 14 | 190406 | PISTON RING ASSEMBLY |
| 15 | 180072 | CONNECTING ROD ASSEMBLY |
| 16 | 190404 | THE PISTON PIN |
| 17 | 180791 | PISTON PIN RETAINER |
| 18 | 180512 | CRANKCASE COVER |
| 19 | 180530 | BEARING |
| 20 | 190225 | CENTRIFUGAL GOVERNOR GEAR ASSEMBLY |
| 21 | 180514 | CYLINDER HEAD |
| 22 | 180794 | INLET VALVE |
| 23 | 180795 | THE EXHAUST VALVE |
| 24 | 180752 | LOWER SEAT OF INLET VALVE SPRING |
| 25 | 180573 | VALVE SEAL |
| 26 | 190224 | VALVE SPRINGS |
| 27 | 170504 | LINE PRESSING BLOCK |
| 28 | 180755 | EXHAUST VALVE SPRING SEAT |
| 29 | NA | LIMIT PLATE ASSEMBLY |
| 30 | 180799 | ROCKER ARM |
| 31 | 180756 | HAT |
| 32 | 140503 | INTAKE STUD |
| 33 | 180571 | EXHAUST STUD |
| 34 | 180522 | EXHAUST GASKET |
| 35 | 180531 | OIL GAUGE ASSEMBLY |
| 36 | 110502 | SPRING WASHERS PHI 8 |
| 37 | 180524 | NUT M8 |
| 38 | 300797 | CARBURETOR ASSEMBLY |
| 39 | 180515 | CONTROL ARM |
| 40 | 180616 | WIRE HARNESS CLIP |
| 41 | 100548 | NUT M6 |
| 42 | 190403 | THE CRANKSHAFT |
| 43 | 190402 | THE VALVE LIFTER |
| 44 | 180511 | CRANKCASE GASKET |
| 45 | 190401 | BALANCE SHAFT |
| 46 | 180806 | CAMSHAFT ASSEMBLY |
| 47 | 180807 | COIL BOLT M8X35 |
| 48 | 180808 | BOLT WITH DISC M8X40 |
| 49 | 180742 | CYLINDER HEAD PIN |
| 50 | 180513 | CYLINDER HEAD GASKET |
| 51 | 180523 | COIL BOLT M10X80 |
| 52 | 180526 | THE SPARK PLUG |
| 53 | 180810 | THE VALVE PUSH ROD |
| 54 | 180811 | WIND DEFLECTOR |
| 55 | 120505 | BOLT WITH DISC M6X12 |
| 56 | 180527 | CYLINDER CRANIUM |
| 57 | 180528 | CYLINDER HEAD COVER GASKET |

| NO. | PART. | DESCRIPTION |
|------|--------|----------------------------------------------------|
| 58 | 180529 | CYLINDER HEAD COVER FASTENING BOLTS |
| 59 | 180519 | SPEED CONTROL CONTROLLER |
| 60 | 180503 | THE FLYWHEEL COMPONENTS |
| 61 | 180502 | THE IMPELLER |
| 62 | 180501 | START THE CUP |
| 63 | 180500 | THE FLYWHEEL NUT |
| 64 | 180510 | RUBBER LEAD |
| 65 | 180584 | IGNITER |
| 66 | 100518 | M6X25 FOOT SCREW FOR PADS TO LEGS |
| 67 | 140504 | INTAKE GASKET |
| 68 | 140502 | INSULATOR,CARBURETOR |
| 69 | 140509 | CARBURETOR GASKET |
| 70 | 180636 | ROCKER ARM FASTENING BOLT ASSEMBLY |
| 71 | 180521 | THE MUFFLER CONNECTS THE PIPE |
| 72 | 180516 | THE THROTTLE LEVER |
| 73 | 180517 | VERNIER C SPRING |
| 74 | 170500 | HOOD ASSEMBLY |
| 74.1 | 100523 | PULL HANDLE |
| 75 | 160500 | AIR FILTER ELEMENT |
| 75.1 | 160006 | AIR CLEANER ELEMENT |
| 76 | 180533 | EXHAUST PIPE |
| 77 | 180518 | SPEED REGULATING SPRING B |
| 78 | 140537 | EMPTY FILTER GASKET |
| 79 | 170502 | Q TYPE LINE CARD |
| 80 | 140506 | FUEL PIPE RUBBER |
| 81 | 170506 | CLAMPER CORD A |
| 82 | 180589 | BOLT WITH DISC M6X8 |
| 83 | 170503 | STARTING MOTOR ASSEMBLY |
| 84 | 180744 | VALVE LOCK CLAMP |
| 85 | 100589 | FUEL PIPE |
| 86 | 140508 | FUEL PIPE CLAMP RING Φ 7.5 |
| 87 | 180506 | CHARGING COIL |
| 88 | 100636 | BOLT M6X30 |
| 89 | NA | Q TYPE LINE CARD |
| NA | 140571 | HIGH ALTITUDE CARBURETOR KIT 420CC (SOLD SEPARATE) |
| NA | 140565 | HIGH ALTITUDE REGULATOR KIT (SOLD SEPARATE) |
| NA | 140008 | FUEL SOLENOID |
| NA | 170040 | STARTING SOLENOID |
| NA | 300504 | SPARK ARRESTOR |
| NA | 210002 | SPARK PLUG TOOL WRENCH |
| NA | 180233 | SPARK PLUG BOOT |

WH1000DF SCHEMATIC

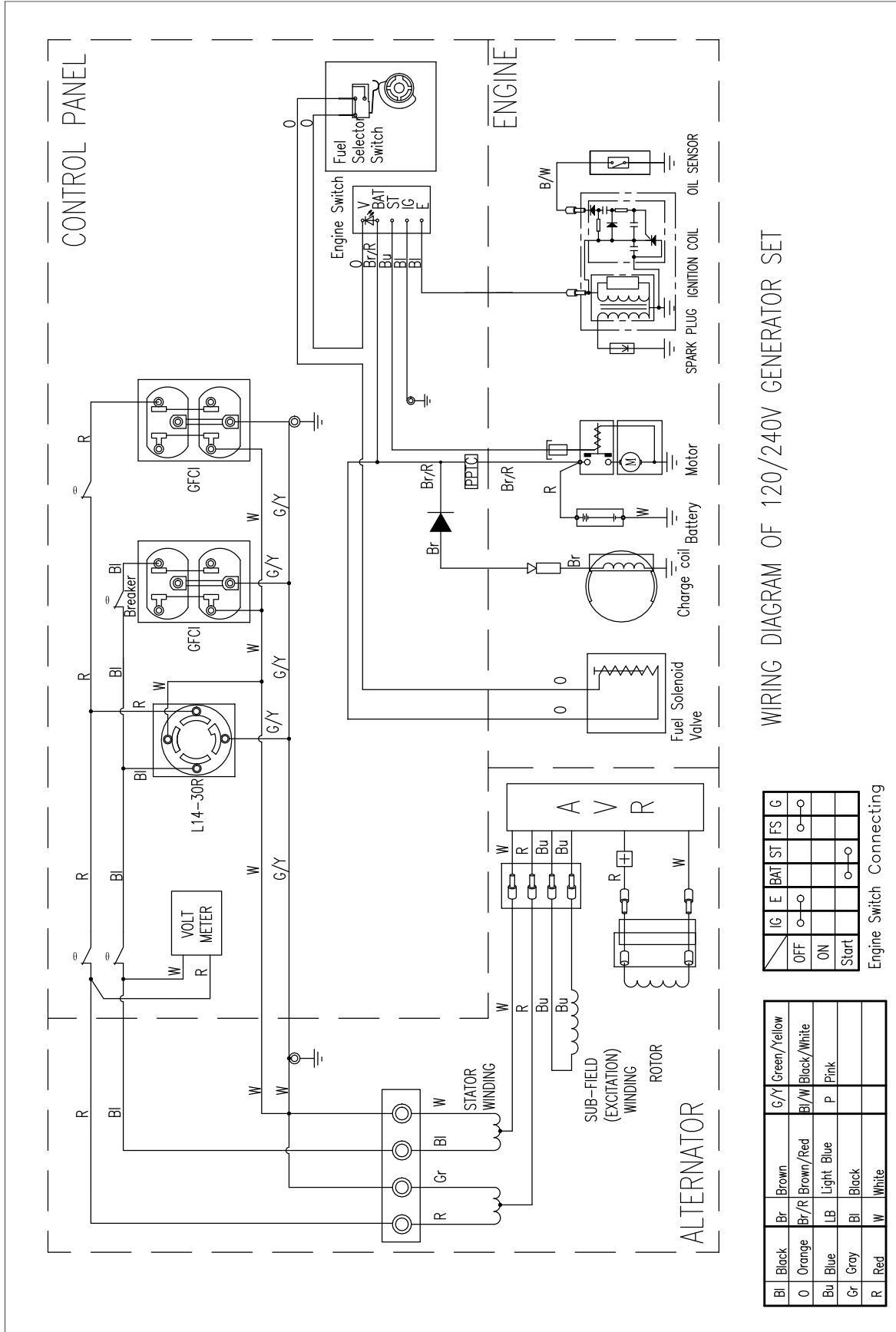

WIRING DIAGRAM OF 120/240V GENERATOR SET

| | | | | | |
|-------|-----|-----|----|-----|---|
| IG | E | BAT | ST | FS | G |
| OFF | o-o | | | o-o | |
| ON | o-o | | | | |
| Start | | | | o-o | |

Engine Switch Connecting

| | | | | | |
|----|--------|------|------------|------|--------------|
| Bl | Black | Br | Brown | G/Y | Green/Yellow |
| O | Orange | Br/R | Brown/Red | Bl/W | Black/White |
| Bu | Blue | LB | Light Blue | P | Pink |
| Gr | Gray | Bl | Black | | |
| R | Red | W | White | | |



WestinghouseOutdoorPower.com

Service Hotline: (855) 944-3571

**777 Manor Park Drive
Columbus, OH 43228**

**™ & © 2019 Westinghouse Electric Corporation
© 2019 Westinghouse Outdoor Power Equipment. All Rights Reserved.**

Part number 10003 Version 07.26.19KD Rev1